

# DOOSAN

Articulated Dump Truck |  
DA30 DA45



Maximum power (ISO 3046): 375 / 500 HP  
Maximum payload: 28 m t (31 s t) / 41 m t (45 s t)  
Body capacity heaped (with tailgate): 17.8 / 26.1 m<sup>3</sup>



# Doosan Group – Building your tomorrow today

## Be part of the great Doosan family

The Doosan Group - founded in 1896 and headquartered in Seoul, South Korea - is one of the fastest-growing companies in the world:

- With more than 37,500 employees in 38 countries, we are a major player in a variety of industries worldwide.
- A global leader in the Infrastructure Support Business (ISB), with 56 subsidiaries and 3,700 distributors worldwide.
- Dramatic growth over the past two decades, with an annual Doosan Group revenue rising from €2.4 billion in 1998 to €12.8 billion in 2016.

## Doosan Group – a top player worldwide



### Doosan Infracore

- Among the world's Top 5 manufacturers of construction equipment



### Doosan Bobcat

- A leading company in the design, manufacture, marketing, distribution and service of small equipment and attachments for construction, agriculture, and landscaping
- Leading position in the global compact equipment market
- N° 1 in North America for SSL, CTL and MEX



### Doosan Heavy Industries & Construction

- World N° 1 in desalination plant construction
- World N° 1 in heat recovery steam generator market
- World N° 1 in mould & tool steel
- World N° 3 in crankshafts



### Doosan Engineering & Construction

- A pioneering leader in construction of residential and public buildings, civil works and industrial facilities.
- World N° 1 chemical process equipment products



## Doosan Infracore Construction Equipment

### Creating construction equipment for over 40 years

For over 40 years, we've been building a global production and business network to become one of the world's foremost construction equipment manufacturers.

### A solid partner, close to you

A truly global player in every respect, we have large-scale factories, sales subsidiaries and dealers all over the world.



Doosan facilities in Europe

▣ **From machine manufacturer... to full solution provider**

To ensure the highest trade-in and residual values, our parts and service support professionals maintain the performance, productivity and reliability that you expect of our products throughout their lifetime.

▣ **Ask your dealer for a full range of services designed especially for you!**

As your local specialist, your dealer ensures that you receive the maximum benefit from our integrated package. Plan ahead to ensure the success of your equipment!



Doosan approved attachments



Genuine parts



Extension of warranty



Financial solutions



Maintenance contract



Telematics



Monitoring systems



Dealer Locator

Europe

Select a country

City, Country

Search

**Dealer locator**

Advanced Services

- Articulated Dump Trucks
- Mini excavator
- Crawler Excavator
- Wheeled Excavator
- Wheel Loaders



▣ **Experience the Doosan product range!**



Articulated Dump Trucks



Wheel Loaders



Wheeled Excavators



Mini Excavators



Crawler Excavators

# Take a tour of the DA30

## ► Productivity

The DA30 offers best-in-class ground clearance & ground bearing pressure. Combined with superior torque at low engine RPM, and superior power and traction, we offer you the best productivity.

⊙ **Operator's environment:** Ergonomic controls, most spacious cab in the market, high-class seat, Bluetooth radio with USB, and much more...

⊙ **Operate at ease:** Upgraded monitor panel, new control panel for more convenient use, real-life payload meter with external light indication, rear-view camera, body tip boost button, etc.

⊙ **Power:** Scania DC 09 engine: 276 kW (370 HP) at 2100 rpm with electronic exhaust brake.

⊙ **New quality of ride:** New self-leveling, hydro-gas suspension supports soft ride in harsh conditions.

⊙ **Maneuverability:** Unique design of rear frame, body, and front-mounted differential on transmission make the Doosan machine the most compact ADT in its class, which results in smallest turning radius and outstanding stability.

⊙ **Differential:** Front and rear differentials are limited slip, longitudinal differential can be manually locked by pushing 1 button.



Some equipment shown on the machine may be optional in your region

⊕ **Safety highlights:** Gradient meter with body flip-over protection, Body Over Centre of Gravity function, fenders and hand rails all around cab, superior stability and always visible and clean front cab access.

⊕ **Body:** Steel plates with 400 HB hardness. Capacity without/with tailgate: 16.8/17.8 m<sup>3</sup>. Tailgate, body heating & wear plates available as optional equipment.

### **DOOSAN** **CONNECT**

⊕ **Telematics:** Monitor your fleet online. As standard, Doosan Connect system with dual mode (satellite, GSM). Check productivity, fuel consumption, system warnings, maintenance status, etc.

⊕ **Brake systems:** Oil-cooled wet disc brakes (lifetime up to 15,000 hours). Standard hydraulic transmission retarder & hydraulic parking brake.

**Service accessibility:** Diesel, AdBlue and grease (for auto-lube system) filling from ground level. Easy access to filters and oil filling points. Tilttable cab with self-positioning locking mechanism.



# Take a tour of the DA45

## ► Productivity

The Doosan DA45 offers the best combination of payload and efficiency in its class. Thanks to its unique design, best productivity is delivered in all working conditions.

⊕ **Operator's environment:** Ergonomic controls, most spacious cab in the market, high-class seat, Bluetooth radio with USB, and much more...

⊕ **Operate at ease:** Upgraded monitor panel, new control panel for more convenient use, real-life payload meter with external light indication, rear-view camera, body tip boost button, etc.

⊕ **Power:** Unstoppable Stage V compliant Scania DC13 engine: 368 kW (500 HP) at 2100 rpm.

⊕ **New quality of ride:** New self-leveling, hydro-gas suspension supports soft ride in harsh conditions.

⊕ **Maneuverability:** Unique design of rear frame, body, and front-mounted differential and transmission make the Doosan machine the most compact ADT in its class, which results in smallest turning radius and outstanding stability.

⊕ **Differentials:** Front and rear differentials are limited slip, longitudinal differential can be manually locked by pushing 1 button.



Some equipment shown on the machine may be optional in your region

⊕ **Safety highlights:** Gradient meter with body flip-over protection, Body Over Centre of Gravity function, fenders and hand rails all around cab, superior stability and always visible and clean front cab access.

⊕ **Body:** Steel plates with 400 HB hardness. Capacity with/without tailgate: 24.5/26.1 m<sup>3</sup>. Tailgate, body heating & wear plates available as optional equipment.



### **DOOSAN** **CONNECT**

⊕ **Telematics:** Monitor your fleet online. As standard, Doosan Connect system with dual mode (satellite, GSM). Check productivity, fuel consumption, system warnings, maintenance status, etc.

⊕ **Brake systems:** Oil-cooled wet disc brakes (lifetime up to 15,000 hours). Standard electronic engine brake, hydraulic transmission retarder & parking brake.

⊕ **Service accessibility:** Diesel, AdBlue and grease (for auto-lube system) filling from ground level. Easy access to filters and oil filling points. Tilttable cab with self-positioning locking mechanism.

# Top performance and fuel efficiency



## ▣ The power to raise productivity

The Doosan ADT concept offers a larger load capacity in all weight categories. Additional load capacity, combined with superior power and traction, improve productivity. The unique advantages of the Doosan ADT's permanent 6-wheel drive, free-swinging rear tandem, front-mounted turning ring, independent front wheel suspension, and sloping rear frame provide excellent driving stability with equal weight distribution and superior traction. The Doosan Articulated Dump Truck is designed to work under very tough conditions and travel up to 55 km/h.



### Engines – lower emissions / same great performance

Doosan ADTs use only proven, reliable and powerful diesel Scania engines with excellent torque, which achieve low fuel consumption and fulfill Stage V European regulation requirements.

### New self-leveling hydro-gas front suspension

The DA30's design was based on the successful and proven design of the DA45. It has been upgraded with the self-leveling system for better shock absorption in changing operating conditions.

### Payload meter

Our standard real-life payload & load count meter provides the Doosan operator and owner with an immediate indication of the productivity. External indication lights help load the body more efficient.

### Downhill speed modulation

Powerful hydraulic retarder keeps machine's speed constant on downhills without support of service brakes. Operator can easily adjust the retarder's power by lever or simply pushing the gas pedal.

### Transportability

Thanks to its less than 3-meter width, the DA30 can be moved easily from one site to another. And thanks to the compact design of both machines, a shorter low loader can be used.

### Forward-mounted turning ring

The turning ring is located in front of the articulation point, ensuring equal weight distribution to the front wheels in all operating situations, including maximum turning. The equal weight distribution enables you to use the limited slip differentials with only 45% locking value - ensuring drive to both front wheels in all situations, without completely locking the wheels.

### Traction

The Doosan ADT's unique design offers permanent 6-wheel drive, ensuring stability and equal weight distribution to accommodate all job applications. The Doosan ADTs superior driveline ensures maximum traction and durability.





Front-mounted articulation hinge

2 limited-slip differentials

1 manual differential lock

Sloping rear frame

Gear-driven tandem axle



**Design simplicity:** Permanent 6-wheel drive, together with the ground-following rear tandem and our special front-mounted turning ring, provide equal power & weight distribution and excellent operating performance. The sloping rear frame provides a lower centre of gravity - improving the ADT's overall stability, and ensuring fast and easy tipping of the body for increased productivity.

# Operate in comfort

## ▣ Quietest truck in the industry

The spacious ROPS/FOPS cab is equipped with climate control and a high-quality operator seat with air suspension to provide excellent comfort. Precise steering, good visibility, low noise levels (72 dB(A), ISO6395) and optional vertical movement provide additional comfort and quiet.

- The sloping hood gives the operator an excellent view
- The cab is mounted on a special rubber suspension to reduce vibration and conduction of noise into the cab



### Best-in-class operator environment

The new DA30 cab was designed based on the feedback received directly from hundreds of Doosan operators. This resulted in upgrade of the cab in features and functions required by the market, including: hand grip on the right side, foot rest, improved storage room, USB charger, Bluetooth radio, all around rails outside the cab, additional lever for retarder control and a number of other new features.

### High-comfort air-suspension seat

Because a highly comfortable seat means a lot to every operator, we provide an air-suspension seat with armrest as standard.

### One key solution

To enter and safely operate your Doosan ADT, you need just 1 key to lock and unlock all the doors and also start the engine.

### Self-leveling, hydro-gas front suspension

New suspension system has outstanding performance in rough terrain due to big shock absorption capacity of the hydraulic suspension cylinders. On top of that, the self-leveling system can adjust to match changing working conditions.

### Storage compartments with extra 12 V power supply

Plenty of storage spaces, plus extra room designed to fit cool/hot box with additional 12V power supply.

### MP3, DAB and Bluetooth

Standard radio supports all modern features like MP3, DAB and Bluetooth

### Climate control

Our specially designed climate control is easy to operate and highly efficient - keeping you comfortable at all times.



Sliding window and hand grip



Retarder control lever



Safety hand rails  
all around the cab

# Total control in all simplicity

## ▣ Operate at ease in your comfort zone

The Doosan ADT is one of the industry's simplest trucks to operate and, at the same, time offers a large number of functions. Comfortably seated in this class-leading operator cab, you'll enjoy easy operation combined with excellent efficiency. And thanks to the upgraded monitor panel, you'll operate in your comfort zone.

- Bigger indications
- Multiple languages
- Integrated payload meter (as standard)
- Diagnostic section with transmission and hydraulic oil level check function
- Gradient meter indication for increased safety while operating
- Integrated rear-view camera

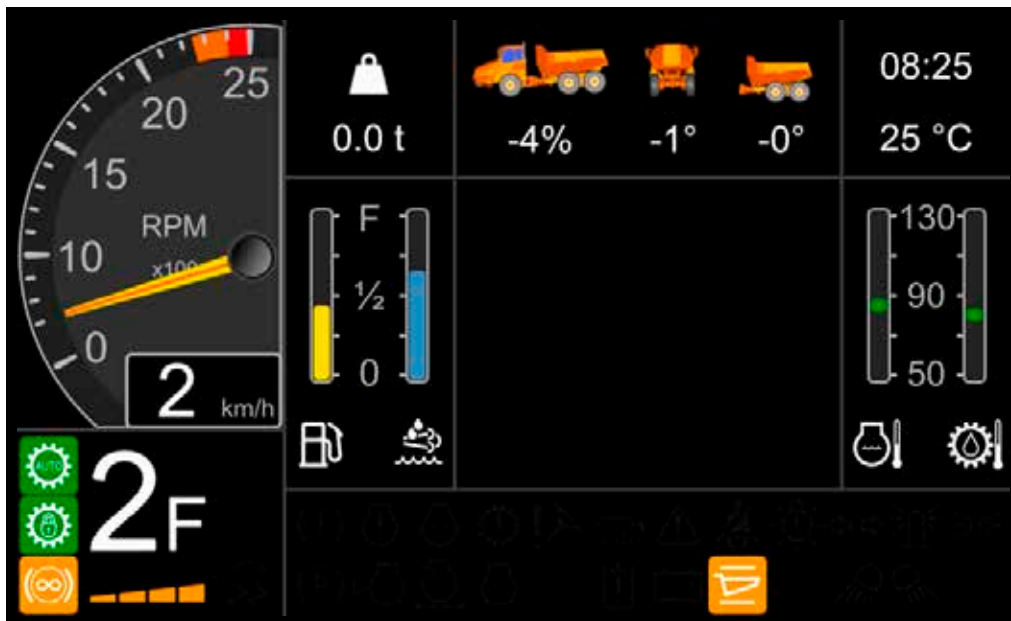

### LCD color monitor panel

- 7" color display, resolution 800 x 480 pixels
- Shows all necessary information for driving and handling the machine
- Rear-view camera image embedded in instrumentation graphics
- Backlight dimming according to ambient light conditions
- Sub-menus for additional and diagnostic functions

### Touch pad

- Diesel fuel heater ON/OFF
- Longitudinal differential lock
- Override button
- Cab roof and mirror arm front lights ON/OFF
- Rotating beacon ON/OFF (optional)
- Operating work-lights ON/OFF

### Differential activation

With automatic limited slip differentials, automatic and manual transmission shift, power steering, "simple touchpad" and "easy to read" display, every ADT is as simple to use & operate as possible.

### Body hoist lever

The new body hoist lever is easy to operate and fingertip controlled. This electronically managed hoist lever incorporates a higher body up speed and an automatic body down feature, with soft touch down, to keep you safe at all times.

### "Tip-tronic" gear shift

To ensure the smoothest possible gear shifts and momentum, you can run the truck in both automatic and manual gears.

### Retarder force modulation lever

New lever located on the right-hand side below the steering wheel enables operator to choose from 4 power modes. On top of that, the gas pedal is responsible for retarder power reduction.

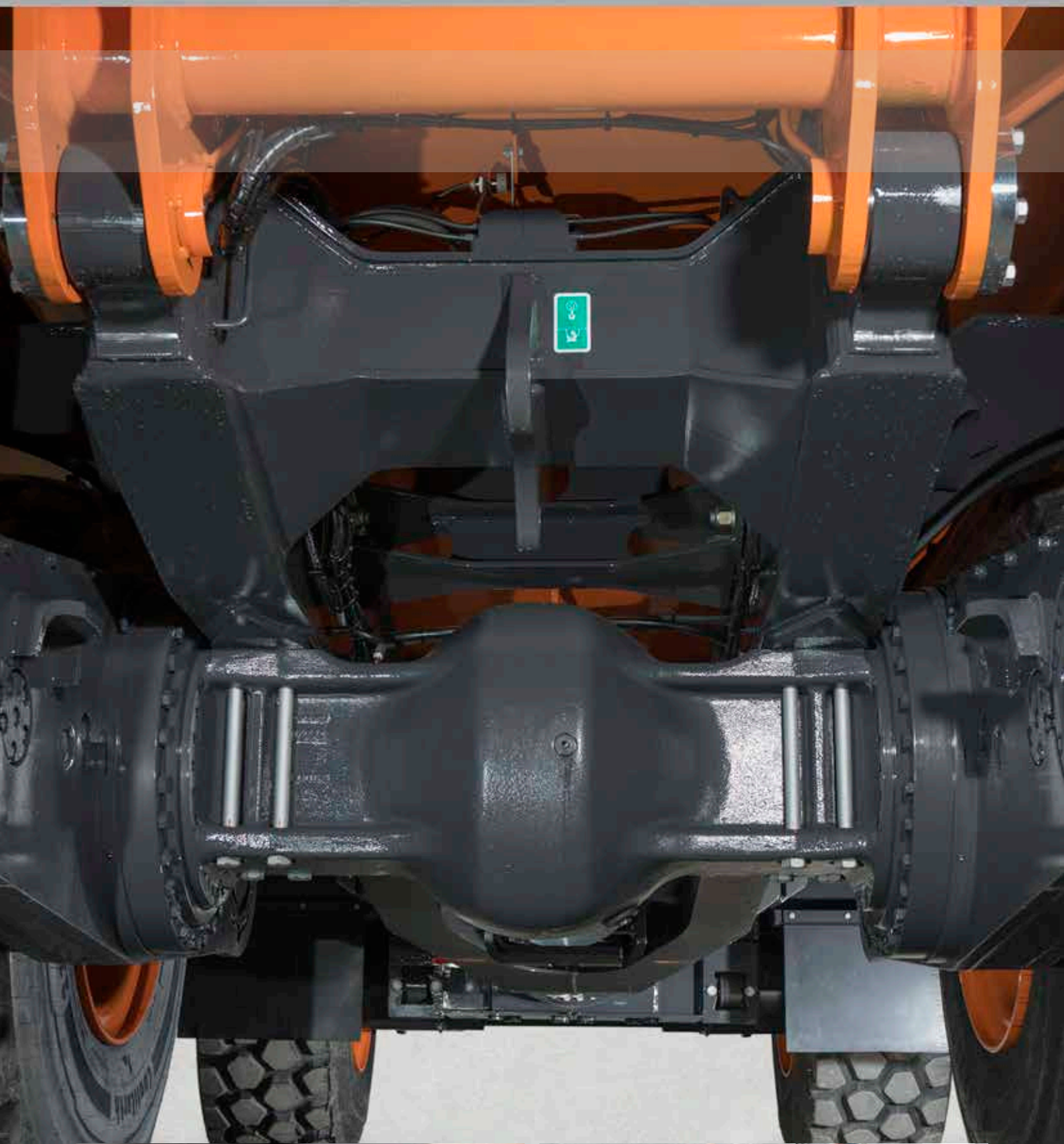

**Body hoist lever with boost button**



**All-round visibility**

# Simple maintenance with great uptime

## Access main filling points while standing on the ground

Improved simplicity of maintenance and service reduces failure rate and improves lifetime and longevity. Convenient position of liquids' levels check and filling points, easy access to filters and very low number of rubber wearing components significantly reduce labor time.



- Easy access to factory-fitted standard automatic central lubrication system
- Dedicated space for grease cartridge and grease gun.
- Easy access to filters



- Diesel and AdBlue filling points accessible from the ground level
- Diesel tank prepared for fast fill coupler



- LED light indicates when power isolator can be switched off
- Power isolator in convenient and safe location
- External power supply



- Multifunctional display with available service/maintenance functions
- Transmission oil level check
- Status of hydraulic and electronic components

## Training Center

Located in the heart of Europe, near Prague (Czech Republic), the Doosan Academy is a dynamic center of knowledge where Product, Service and Doosan University training courses are held.

The facilities include a modern building that can accommodate all of the product ranges, and an outdoor training area where we conduct field exercises and product testing with the fleet of Doosan machines and attachments.

## Filters

All filters are centralized for quicker and easier accessibility.

## Global Doosan network

With a network of Doosan Dealers & Parts Distribution Centers worldwide, your Doosan trucks can be serviced & maintained wherever you are.

## Telematics

The Doosan Connect system is available for reading out vehicle operating & production parameters remotely, and providing you with total ease-of-mind. Keep day-by-day overview on the machine's productivity, status and condition.



**WORK EFFICIENCY  
MANAGEMENT**

**JOB SITE  
MANAGEMENT**

**PROACTIVE  
SERVICE**

**PREVENTIVE  
MAINTENANCE**

**OPERATION TREND**

Total operation hours and operation hours by mode

**FUEL EFFICIENCY\***

Fuel level and fuel consumption

**LOCATION**

GPS and geo-fence

**REPORTS**

Operation report & utilization

**WARNING & ALERT**

Detect machine warnings, antenna disconnection, and geo/time fence

**FILTER & OIL MANAGEMENT**

Preventive maintenance by item replacement cycle

**TELEMATICS TERMINAL**

Terminal device is installed and connected to a machine to get machine data.

**TELECOMMUNICATION**

Doosan provides Dual mode (Mobile, Satellite) communication to maximize communication coverage.

**DOOSANCONNECT WEB**

Users can monitor machine status from DoosanCONNECT Web.

# Technical specifications

## Body

	DA30	DA45
Body volume (without tailgate)	16.8 m <sup>3</sup> – 23.3 yd <sup>3</sup>	24.4 m <sup>3</sup> – 31.9 yd <sup>3</sup>
Material	Hardened abrasion-resistant steel plates (400 HB)	
Tilt cylinders	Single stage, double-acting	
Tipping time	Up: 12 sec. / Down: 10 sec.	
Body	Designed for exhaust heating	
Sloping frame	Down from the hinge point	
Level capacity (with / without tailgate)	14.2 m <sup>3</sup> / 13.6 m <sup>3</sup> – 18.6 yd <sup>3</sup> / 17.8 yd <sup>3</sup>	20.4 m <sup>3</sup> / 19.6 m <sup>3</sup> – 26.7 yd <sup>3</sup> / 25.6 yd <sup>3</sup>
Heaped capacity (with / without tailgate)	17.8 m <sup>3</sup> / 16.8 m <sup>3</sup> – 23.3 yd <sup>3</sup> / 22.0 yd <sup>3</sup>	26.1 m <sup>3</sup> / 24.6 m <sup>3</sup> – 47.1 yd <sup>3</sup> / 31.9 yd <sup>3</sup>

## Weights

Empty: Front axle	12500 kg – 27558 lb	14500 kg – 31967 lb
Empty: Rear axle	10600 kg – 23369 lb	16000 kg – 35274 lb
Max. admissible axle load: Front axle	16700 kg – 36817 lb	22500 kg – 49604 lb
Max. admissible axle load: Rear axle	37000 kg – 81571 lb	55000 kg – 121254 lb
Max. admissible weight	51500 kg – 113538 lb	71500 kg – 157631 lb
Payload	28 metric ton – 31 short ton	41 metric ton – 45 short ton
Net weight	23100 kg – 50928 lb	30500 kg – 67241 lb

NOTE: All weights include a full fuel tank and operator.

## Power to weight ratio (Net Power vs Ton)

Empty	11.9 kW/t	11.8 kW/t
Loaded	5.4 kW/t	5.0 kW/t

## Ground pressure

	Standard 23.5 × 25 tyres with 15% sinkage	Standard 29.5 × 25 tyres with 15% sinkage
Empty: Front axle	121.7 kPa – 17.65 psi	93.9 kPa – 13.62 psi
Empty: Rear axle	51.6 kPa – 7.48 psi	51.8 kPa – 7.51 psi
Loaded: Front axle	161.6 kPa – 23.44 psi	139.2 kPa – 20.19 psi
Loaded: Rear axle	169.8 kPa – 24.63 psi	161.3 kPa – 23.39 psi

## Capacities

Fuel tank	360 l	500 l
Hydraulic system	75 l	85 l
Adblue tank	70 l	70 l
Hub front	11	9,6
Tandem housing, rear differential and hubs	145,3	228
Cooling circuit	35	35
Engine	35	45

## Speeds

	Forward – Reverse	Forward – Reverse
Forward 1 – 2 – 3 – 4 – 5 – 6 – 7 – 8	6 - 8 - 11 - 16 - 23 - 32 - 45 - 55 km/h	5 - 8 - 11 - 16 - 23 - 32 - 45 - 55 km/h
Rear 1 – 2 – 3 – 4	6 - 8 - 11 - 16 km/h	5 - 8 - 11 - 16 km/h

## Engine

Complies with Stage V of EU Directive 97/68/EC for emissions	Scania DC 9, water-cooled, diesel engine with turbo charger and air-to-air intercooler	Scania DC 13, water-cooled, diesel engine with turbo charger and air-to-air intercooler
Power rating ISO 3046 / ISO 14396 @ 2100 rpm	375 HP (276 kW) / 362 HP (270 kW)	500 hp (368 kW) / 483 hp (360 kW)
No. of cylinders	5 (in line)	6 (in line)
Gross Torque	1873 Nm @ 1300 rpm	2373 Nm @ 1300 rpm
Cylinder volume	9.3 litres	12.7 litres
Bore diameter × stroke	130 × 140 mm	130 × 160 mm
Air filter	Dry type	Dry type

## Transmission

Electronically-controlled automatic transmission with retarder. The torque converter has automatic lock-up in all gears.	ZF 8 EP320	ZF 8 EP420
--	------------	------------

## Hydraulic system

1 variable displacement piston pump for steering & tipping for cooling fan, brakes & auxiliaries	305 l/min @ 2100 rpm
Filtration	One return flow filter
Main safety valves pressures, tipping / steering circuit	280 / 210 bar

## Electrical system

Batteries	2 × 12V 140Ah (series connected to give 24V)
Starter	8 HP (6 kW)
Alternator	24V 100A

## Tires

Standard	23,5 R25 two star radial	29,5 R25 two star radial
----------	--------------------------	--------------------------



DA30

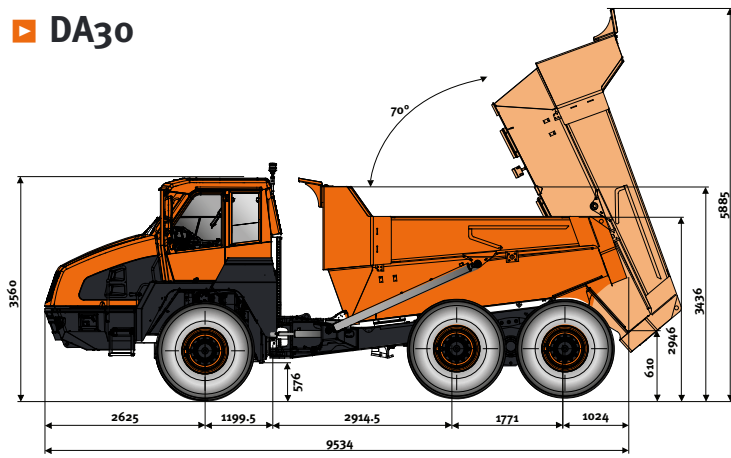

Unit: mm

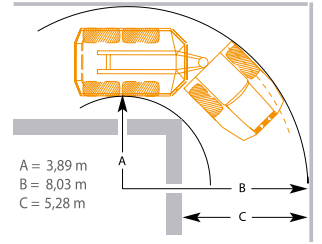
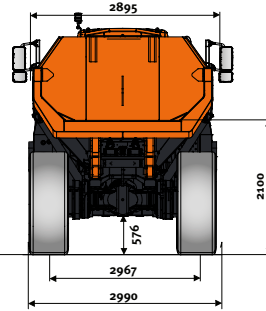

DA30 width with 750/65 R25 tyres: 3208 mm

Turning radius according to ISO 7457: 7.68 m

DA45

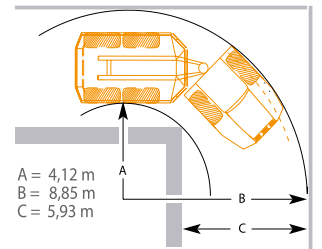
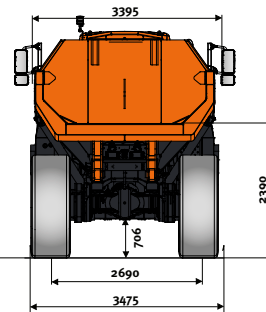
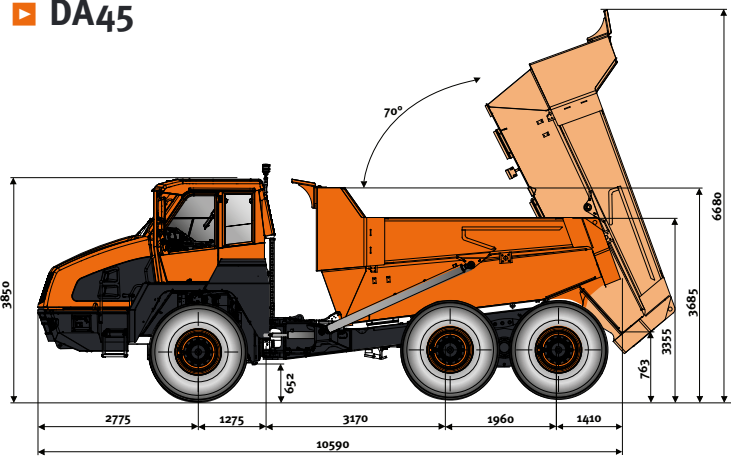

DA45 width with 875/65 R29 tyres: 3630 mm

Turning radius according to ISO 7457: 8.42 m



# Special features

## DA30/DA45 special features

### Suspension

- ▶ Front: Semi-independent, self-leveling hydro-gas suspension.
- ▶ Rear: Free-swinging tandem housing.

### Articulation hinge and steering

- ▶ Articulation hinge with forward-mounted turning ring.
- ▶ Steering cylinders (two): Double-acting.
- ▶ The steering is approved according to ISO 5010.
- ▶ Max. steering angle: 45°.
- ▶ Ground-driven emergency steering pump.

### Driveline

- ▶ Full-time 6 × 6 drive with two transverse differentials and one longitudinal.
- ▶ Front axle transverse differential: Limited-slip diff lock with 45% locking ratio.
- ▶ Rear axle transverse differential: Limited-slip diff lock with 45% locking ratio.
- ▶ Inter-axle longitudinal differential:
  - Torque-proportioning differential, integrated into the ZF transmission.
  - Torque distribution:
    - 1/3 to the front axle
    - 2/3 to the rear axle
    - 100 % lockable
- ▶ Tandem housing: Gear driven, free-swinging.

Provides equal drive to rear wheels and ensures the best possible ground contact – whatever the ground conditions.

### Brake system

- ▶ Dual circuit braking system acting on all six wheels.
- ▶ Approved according to ISO 3450.
- ▶ All hydraulic-operated brakes with enclosed oil-cooled wet multiple discs on four hubs (braking force distributed to two hubs by tandem gear wheels)
- ▶ Spring actuated hydraulic released parking brake, mounted on driveline shaft.
- ▶ Max. gradient, parking brake: 20°.
- ▶ Automatic transmission retarder as standard.

### Cab

- ▶ Approved to ROPS/FOPS standards (ISO 3471, ISO 3449).
- ▶ Low interior sound level: 71 dB(A) (ISO 6395).
- ▶ External sound level: 108 dB(A) (ISO 6396).
- ▶ The cab is centrally located on rubber mountings.
- ▶ Hand and arm vibrations are less than 2.5 ms<sup>2</sup> (ISO 5349-2).
- ▶ Whole body vibration is less than 0.5 ms<sup>2</sup> according to ISO 2631-1.
- ▶ Superior visibility - for safer operation.
- ▶ Superior operating controls location.
- ▶ Adjustable suspended operator seat.
- ▶ Adjustable steering column.
- ▶ Climate control – Heater and air conditioning.
- ▶ Tilting for service access.
- ▶ All-around hand rails.



# Standard and optional equipment

## Engine

	DA30	DA45
Scania, Stage V compliant, SCR, DPF, water-cooled, diesel engine with VGT turbo charger and air-to-air intercooler	●	●

## Hydraulic system

1 variable displacement piston pump for steering & tipping	●	●
One return flow filter	●	●

## Cab & Interior

Armrest at operator seat	●	●
Headrest at operator seat	●	●
Safety belt at operator and instructor seat	●	●
Adjustable steering column	●	●
All instrumentation in LCD display	●	●
Cigarette lighter	●	●
12V and USB charging point	●	●
Retractable roller sunblind	●	●
Tinted safety glass	●	●
Sliding window (left & right side)	●	●
Windshield wiper and washer	●	●
Side mirrors	●	●
Protection for rear window	●	●
Emergency steering, ground-driven	●	●
Radio/MP3 and Bluetooth	●	●
Cab tilting system	●	●
Emergency shutdown switch	●	●
Anti-slip steps & platform	●	●
Cool box compartment	●	●
Storage room	●	●
Electronic climate control	●	●
High-comfort seat (vertical and longitudinal suspension)	●	●
Heated operator seat	●	●
Heated mirror	●	●
Electrically adjustable mirrors	●	●

## Safety

Gradient meter with anti-flip-over protection system	●	●
Payload meter & cycle counter	●	●
Wet disc brake	●	●
Rear-view camera	●	●
Hammer for emergency escape	●	●
Hand rails on the fenders	●	●
Seat belt green warning light	○	○
Blue or orange flashing reverse light	○	○
White noise alarm	○	○

## Other

Transmission retarder brake	●	●
Automatic lubrication system	●	●
Mud flaps	●	●
Towing hook, front and rear	●	●
Doosan Connect Telematic system	●	●
Work light kit (rear and front)	●	●
Tail gate	○	○
Webasto heating system (heat up the cooling system)	○	○
Electrical engine heater	○	○
Fire extinguisher	○	○
First aid kit	○	○
Beacon	○	○
Light bar	○	○
Speed limitation	○	○
Work light kit (rear and front) LED	○	○
Tool kit	○	○
Warning triangle	○	○
Fast fill	○	○
Tire pressure monitoring system (may not be available with all tires)	○	○
Electric diesel refueling pump	○	○

## Tires options

Quarry	○	○
Earthmoving	○	○
Flotation tires	○	○

Standard: ●  
Optional: ○

Some of these options may be standard in some markets. Some of these options may not be available for certain markets. Please check with your local DOOSAN dealer for more information about availability or to adapt your machine to your application needs.



Tail gate



LED lights



Quarry tires

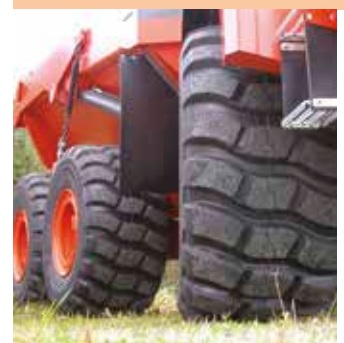

High flotation tires

