

CONE CRUSHER



WORKS FOR YOU.™

C-1540

The Terex Finlay C-1540 tracked mobile cone crusher has a proven pedigree in aggregate and ore surface mining applications. This efficient and productive machine incorporates the proven Terex® 1000 cone crusher with direct variable hydrostatic drive, automatic tramp relief and hydraulic closed side setting (CSS) adjustment.

The Terex Finlay C-1540 can be fitted with an optional patented pre-screen module which allows fines materials to bypass prior to being fed to the crushing chamber offering better wear rates in the crushing chamber. The large hopper/feeder has an automated metal detection and a purge system to protect the cone and reduce downtime by removing metal contaminants via the purge chute.

Additional benefits include, rapid set up time, ease of maintenance, high reduction ratio, high output capacity and advanced electronic control system.

STANDARD FEATURES

Engine:

Tier 3 / Stage IIIA: CAT C9 Acert 350hp (261kW)

Tier 4i / Stage IIIB: Scania DC9 77A 350hp (257kW) (EU SPEC)

Cone:

Terex 1000 Cone chamber, 1000mm (40") head diameter

Long throw eccentric, medium coarse concave (max feed size 160mm)

Hydrostatic cone drive

Hopper / Feeder:

Hopper capacity: 5m³ (6.5yd³)

Belt width: 1.05m (42")

Metal detector

Metal contaminants purge system

Wear resistant liner plates

Main Conveyor:

Belt width: 900mm (36")

High spec scraper at head drum

Wear resistant liners at crusher discharge point

Dust Covers

General:

Galvanised catwalk c/w handrail, kick board and access ladders

Heavy duty track unit, sprocket centres 3.8m, pad width 500mm

Hand held track control set with connection lead

Single speed tracking

Safety guards in compliance to machinery directive

Two auxiliary drives

Emergency stops

Piped for dust suppression c/w spraybars

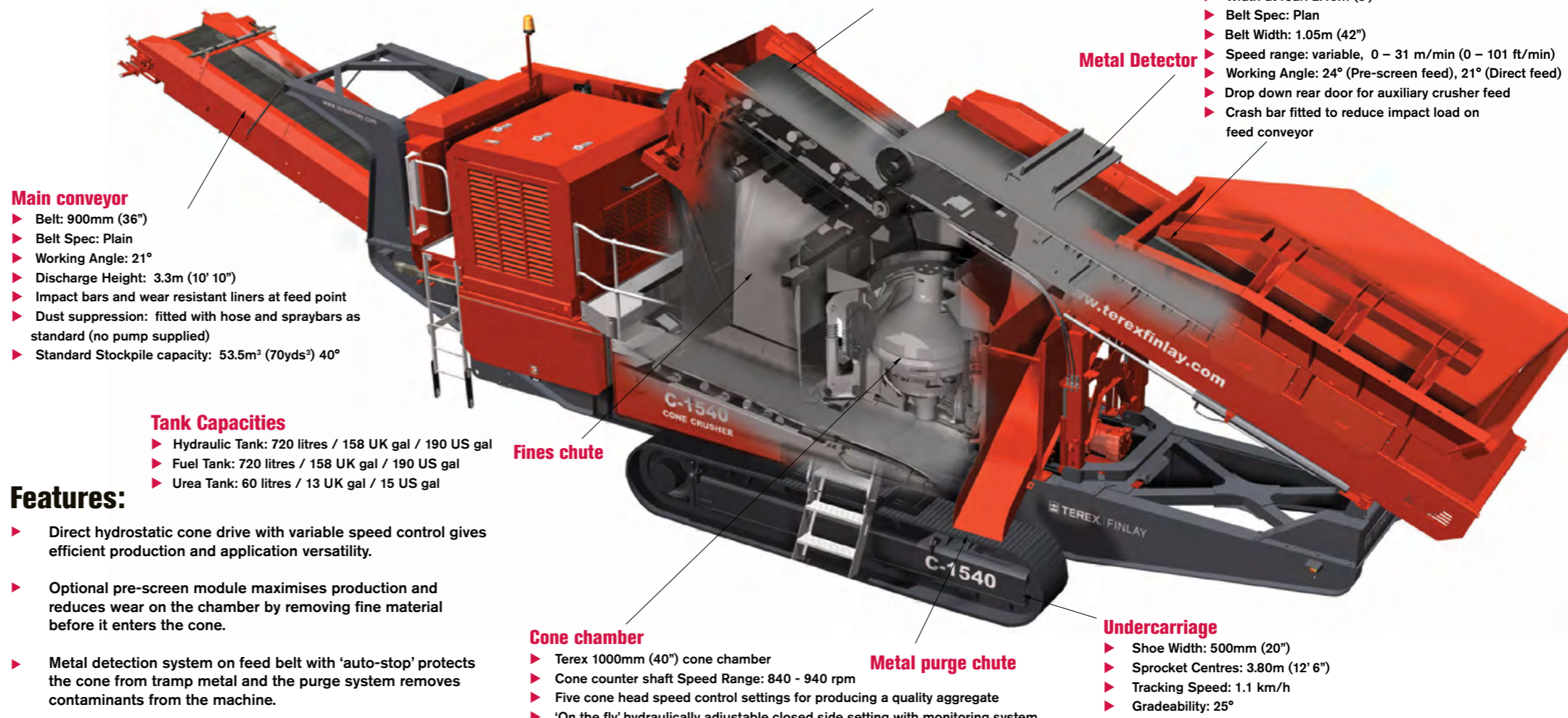

Main conveyor

- ▶ Belt: 900mm (36")
- ▶ Belt Spec: Plain
- ▶ Working Angle: 21°
- ▶ Discharge Height: 3.3m (10' 10")
- ▶ Impact bars and wear resistant liners at feed point
- ▶ Dust suppression: fitted with hose and spraybars as standard (no pump supplied)
- ▶ Standard Stockpile capacity: 53.5m³ (70yds³) 40°

Tank Capacities

- ▶ Hydraulic Tank: 720 litres / 158 UK gal / 190 US gal
- ▶ Fuel Tank: 720 litres / 158 UK gal / 190 US gal
- ▶ Urea Tank: 60 litres / 13 UK gal / 15 US gal

Features:

- ▶ Direct hydrostatic cone drive with variable speed control gives efficient production and application versatility.
- ▶ Optional pre-screen module maximises production and reduces wear on the chamber by removing fine material before it enters the cone.
- ▶ Metal detection system on feed belt with 'auto-stop' protects the cone from tramp metal and the purge system removes contaminants from the machine.
- ▶ Pre-screen system (optional)
 - ▶ Top deck: 1.83m x 1.22m (6' x 4')
 - ▶ Screen Angle: 25°
 - ▶ Screen speed: 1200 rpm
 - ▶ The pre-screen module will maximise production through the cone by removing as much fine material as possible before it enters the cone chamber. This will also reduce wear within the cone chamber
- ▶ Hopper / Feeder
 - ▶ Hopper capacity: 5m³ (6.5yd³)
 - ▶ Hopper fabricated in 10mm mild steel plate with 10mm wear resistant steel liners at input point
 - ▶ Width at rear: 2.45m (8')
 - ▶ Belt Spec: Plain
 - ▶ Belt Width: 1.05m (42")
 - ▶ Speed range: variable, 0 – 31 m/min (0 – 101 ft/min)
 - ▶ Working Angle: 24° (Pre-screen feed), 21° (Direct feed)
 - ▶ Drop down rear door for auxiliary crusher feed
 - ▶ Crash bar fitted to reduce impact load on feed conveyor
- ▶ Metal Detector
- ▶ Metal purge chute
 - ▶ Terex 1000mm (40") cone chamber
 - ▶ Cone counter shaft Speed Range: 840 - 940 rpm
 - ▶ Five cone head speed control settings for producing a quality aggregate
 - ▶ 'On the fly' hydraulically adjustable closed side setting with monitoring system
- ▶ Cone chamber
- ▶ Undercarriage
 - ▶ Shoe Width: 500mm (20")
 - ▶ Sprocket Centres: 3.80m (12' 6")
 - ▶ Tracking Speed: 1.1 km/h
 - ▶ Gradeability: 25°



Transport Dimensions



Working Dimensions



Machine Weight:
36,500Kg (80,469lbs) without options
38,300Kg (84,437lbs) with optional pre-screen

Follow us on:



www.terexfinlay.com

Effective January 2014. Product specifications and prices are subject to change without notice or obligation. The photographs and/or drawings in this document are for illustrative purposes only. Refer to the appropriate Operator's Manual for instructions on the proper use of this equipment. Failure to follow the appropriate Operator's Manual when using our equipment or to otherwise act irresponsibly may result in serious injury or death. The only warranty applicable to our equipment is the standard written warranty applicable to the particular product and sale and Terex GB Ltd. makes no other warranty, express or implied. Products and services listed may be trademarks, service marks or trade-names of Terex Corporation and/or its subsidiaries in the USA and other countries. All rights are reserved. Terex® is a registered trademark of Terex Corporation in the USA and many other countries. Copyright 2010 Terex GB Ltd.



TEREX | FINLAY

WORKS FOR YOU.™