

SPECIFICATIONS

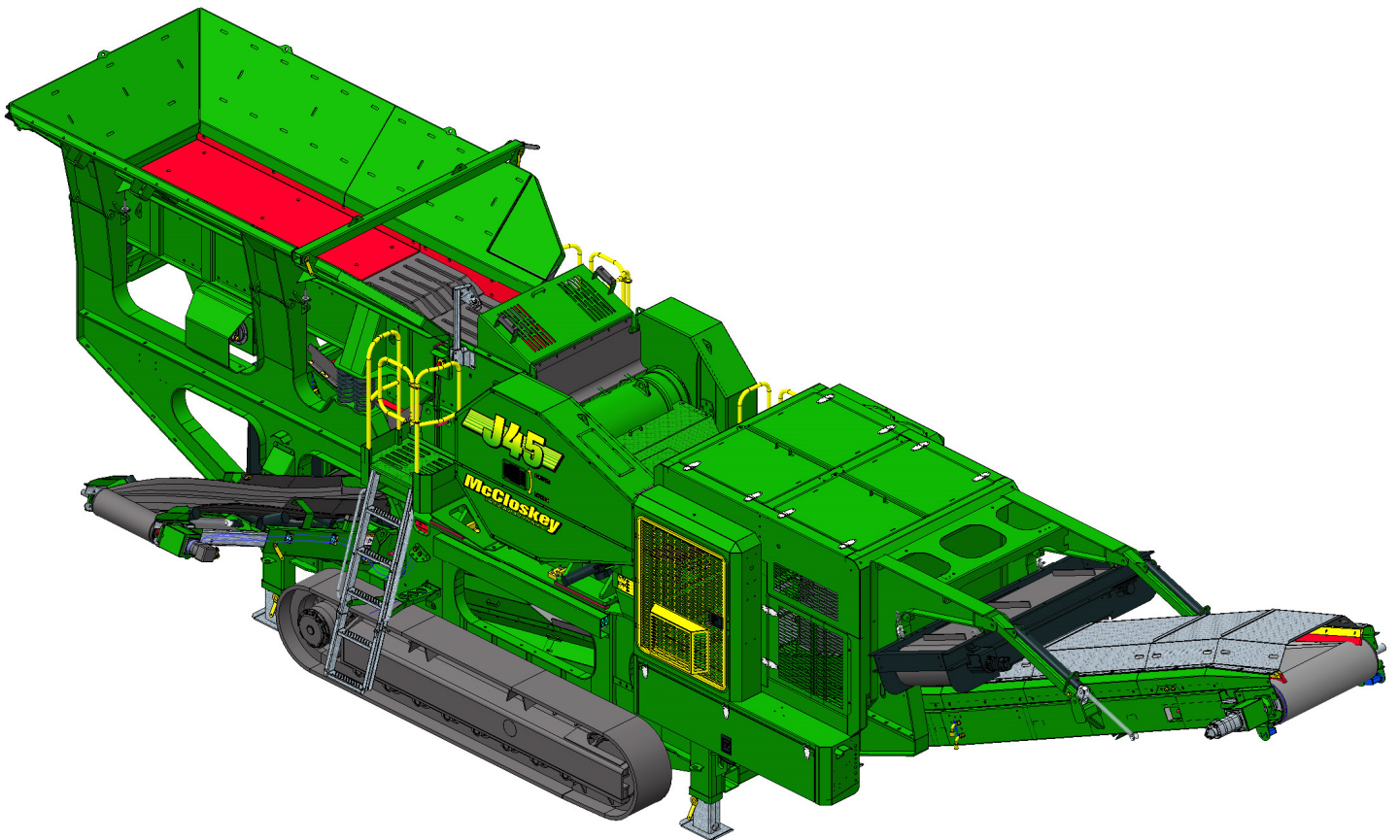
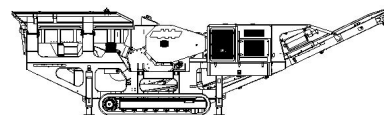

McCloskey

J45

**DESCRIPTION**

Heavy duty track mounted Crusher with following features:

- 1118 (45") x 685 (27") single toggle jaw.
- 350Hp C9 / C9.3 Cat engine.
- Track or Track c/w Wheel bogie.
- Integrated hydraulic folding hopper.
- Integrated hydraulic folding stockpiling conveyors.
- I-beam plate fabricated chassis construction.
- Large gap between crusher discharge and main conveyor feedboot
- Open chassis design for ease of maintenance
- Fast setup time

DIMENSIONS AND WEIGHTS

Length - working	14.350m (47' - 1")
Length - transport	14.476m (47' - 5.9")
Width - transport	2.5m (8' - 2.5")
Height - transport	3.4m (11' - 1.8")
Weight	43,900 Kgs (96,783 lbs) inc. Magnet and Side conveyor

CAPACITIES

Diesel tank capacity	636 L (168 US gal)
Hydraulic tank capacity	1200 L (317 US Gals)

CRUSHING CHAMBER

Feed opening	1140 (45") x 688 (27") (peak to trough)
Crusher speed	300 rpm
Crusher Drive	Hydraulic - Banded V-Belts
Min. opening	51mm (2") *Note Applications
Max. opening	157mm (6.25") (peak to peak)
Jaw weight	15,246Kgs
Closed side setting adjustment	Twin hydraulic ram wedge adjust system
Motor	Kawasaki axial piston 530cc/rev
Flow rate	410 Lpm (108.3 US gpm)
Level sensor	YES (Ultrasonic)
Load sensor	Hydraulic pressure

GRIZZLY FEEDER (std)

Feeder width	1064mm (41.9")
Feeder length	4240mm (13' - 11")
Drive	Hydraulic direct drive
Grizzly section opening (std)	Tapered 35-70mm (1.4" - 2.75")
Grizzly section opening (option)	Tapered 25-50mm (1" - 2")
Grizzly section length	1325mm (52.2")
Motor	David Brown MCC 2208 58.7cc/rev
Flow rate	62.7 Lpm (16.6 US gpm)
Adjustable speed	Yes
Maximum speed	960rpm

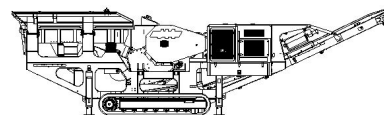
**PAN FEEDER (option)**

Feeder width	1064mm (41.9")
Feeder length	2460mm (8' – 1")
Drive	Hydraulic direct drive
Motor	David Brown MCC 2208 58.7cc/rev
Flow rate	62.7 Lpm (16.6 US gpm)
Adjustable speed	Yes
Maximum speed	960rpm

PRE SCREEN (option)

Prescreen width	1064mm (41.9")
Prescreen length	1920mm (6' – 3.5")
Drive	Hydraulic direct drive
Grizzly section opening (std)	Tapered 35-70mm (1.4" – 2.75")
Grizzly section opening (option)	Tapered 25-50mm (1" – 2")
Grizzly section length	1672mm (65.8")
Motor	David Brown MCC 2208 58.7cc/rev
Flow rate	62.7 Lpm (16.6 US gpm)
Adjustable speed	NO
Maximum speed	970rpm

HOPPER

Length	4530mm (14' – 10.2")
Width	2222mm (7' – 3.4")
Volume	6.8m ³ (8.9yd ³)
Material	8mm sides + 8mm Hardox liners
Locking system	Wedge type and toggle

SIDE CONVEYOR

Stockpile height	2500mm (8' – 2.3")
Belt width	650mm (26")
Belt spec	EP 400/3 3+1.5
Drive drum dia.	220mm (8.6")
Tail drum dia.	220mm (8.6") - spoked
Motor	OMT400
Flow rate	43.7 Lpm (11.5 US gpm)
Adjustable speed	YES
Maximum speed	109 rpm
Hydraulic Telescopic	YES

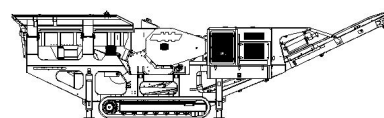
**MAIN CONVEYOR**

Stockpile height	3880mm (12' – 8.7")
Belt width	1050mm (42")
Belt spec	Plain EP500/3 8+2 BREAKER DIN Y
Drive drum dia.	285mm (11.2")
Tail drum dia.	270mm (10.6") - spoked
Motor	OMV630
Flow rate	87.4 Lpm (23.1 US gpm)
Maximum speed	138.7 rpm
Angle adjustable	YES
Quick release	YES

POWERUNIT AND HYDRAULICS

Engine Tier 3 Option	CAT C9
Engine Teir 4i Option	CAT C9.3
Engine power Tier 3 Option	205 kW (275 HP)
Engine power Tier 4i Option	261 kW (350 HP)
Engine speed	1900 rpm
Flywheel Pump 1	Kawasaki K3V140DT (set at 83cc/rev)
LH PTO Pump 2	Turolla 5033 5023 5011
Front PTO Pump 3	David Brown 5046
Total system flow	535.8 Lpm (141.5 US Gpm)
Hydraulic tank capacity	1200 L (317 US Gals)
Hydraulic tank ratio	1.87 : 1
Hydraulic Oil cooler	YES

ELECTRICS

Emergency stops	4 off, 2 feeder, 2 powerunit
Chassis cabling	Armored cable
Start Siren	YES - 10 sec delay
Control panel	Tedd Engineering / IFM
Engine shutdowns:	Low oil pressure High water temp Low hydraulic tank level High hydraulic oil temperature
Radio control tracks and feeder	STANDARD
Pendant track control	YES - plugged in control cabinet

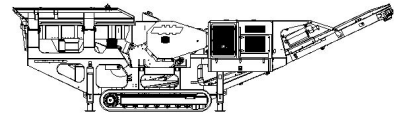
**TRACKS**

Width	400mm (15.7")
Length	4194mm (13' - 9") crs
Height	820mm (32.3")
Gearbox	O&K F55
Ratio	148:1
Motor	Integrated 90cc/rev
Speed max	1.8 Kph (1.1 Mph)
Flow rate	100 Lpm (26.4 US gpm)
Attachment to chassis	Bolt On for quick change

OPTIONS

Roll-in bogie system	
50mm or 70mm Aperture Bofor	
Main conveyor variable speed control	
Hopper Extensions	
Overband magnet	
Water Pump and dust suppression system	
Diesel refueling pump	
Square tooth quarry dies	
30mm corrugated dies	
50mm corrugated dies	
Multitooth dies	
Crusher Deflector Plate – (Belt Protection)	
High level side walkways	STANDARD
Separate pre-screen and pan feeder	

SAFETY FEATURES

External belt alignment points
External grease points
Engine safety shutdown systems
Full safety guarding for nip points

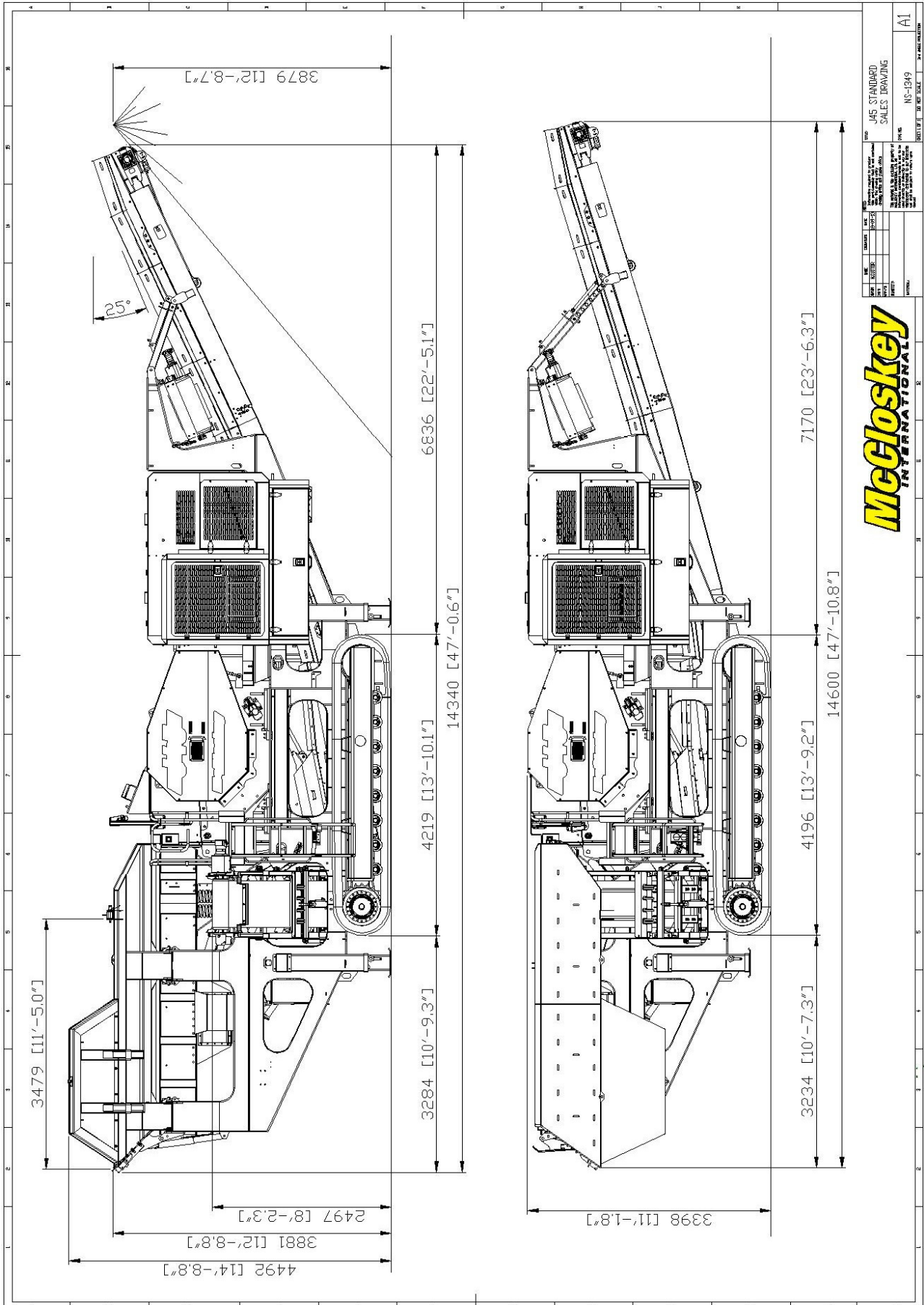
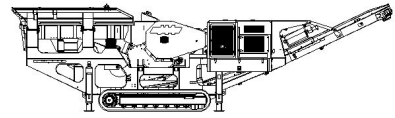

McCloskey
INTERNATIONAL

REV	DATE	BY	CHKD	APP'D
1	03/13/14			
J45 STANDARD SALES DRAWING				
NS-1349				A1

