



Powerscreen International. Dist. Ltd.  
Coalisland Road, Dungannon,  
Co. Tyrone, N. Ireland BT71 4DR  
Tel: +44(0) 2887 740701  
Fax: +44(0) 2887 746569  
Email: [mail@powerscreen.com](mailto:mail@powerscreen.com)

# *INTRODUCING THE WARRIOR 1400*

## JACK UP SCREENBOX



All specifications subject to change without prior notice.

# Technical Specification



WARRIOR 1400 24-01-2007

Page 2

## FEATURES

- |                              |                                     |
|------------------------------|-------------------------------------|
| • Total weight (Belt Feeder) | 25,600 kg (28.22 US Ton) ESTIMATED  |
| • Width (transport)          | 2.75 m (9')                         |
| • Length (transport)         | 14.25 m (46'-9")                    |
| • Length (working)           | 13.51 m (44'-4")                    |
| • Height (transport)         | 3.2 m (10'6")                       |
| • Hopper capacity            | 6.78 m <sup>3</sup> (8.87 cu. yds.) |
| • Screenunit                 | 2-bearing 3.6m x 1.5m (12'x5')      |
| • Powerunit                  | Diesel Hydraulic.                   |

## ADVANTAGES

- High capacity, up to 500 TPH (depending on mesh sizes and material type).
- Quick set up time typically under 15 minutes.
- Maximum mobility with heavy duty, low ground pressure crawler tracks.
- Removable heavy duty pendant remote control system.
- Optional radio control system available if required.
- High performance hydraulic system – Quality pumps and motors with commercial hydraulic control valves.
- Access walkway for screenbox.
- Hydraulically folding hopper sides
- Heavy-duty 2-bearing screen box with 10mm stroke (optional 12mm stroke)
- Hopper exit opening 1.2m wide enabling screening of large items i.e. tree stumps, logs, boulders, etc.
- Screenbox lifts to allow access to change bottom deck mesh

## APPLICATIONS

- Sand and gravel
- Topsoil
- Coal
- Crushed stone
- Recycling
- Compost

# Technical Specification



WARRIOR 1400 24-01-2007

Page 3

## **Hopper:**

Target area: 4.4m long x 2.7m wide.  
Hopper capacity: 6.78 m<sup>3</sup> (8.87 yrd<sup>3</sup>)  
Feed in height: 2.88m (rear hopper door lowered)  
Hardox side plates.  
Lowering section to rear to reduce feed in height for smaller crushers.

## **Screenunit:**

12' x 5' (3.6 x 1.5m) double deck 2-bearing.  
15 to 18 degrees screen angle adjustable.  
Self adjusting motor stand.  
10mm stroke @ 920 ±10 RPM  
12mm stroke @ 860 ±10 RPM

## **Feed Conveyor:**

1300mm (51") wide 4-ply plain belt. Direct feed conveyor fitted with twin direct drive system & hydraulic variable speed control.  
Impact bars and 5 off 'extra heavy' duty impact rollers fitted beneath belt.  
3.43m (11'-3") drum centres.  
Optional 1300mm hardox apron feeder.

## **Collection Conveyor below screenbox:**

1200mm (48") wide 3ply plain belt.  
2.80m (9'-2") drum centres.

## **Fines Conveyor:**

900mm (36") wide 3-ply plain belt.  
Hydraulically folding.  
14 to 25 degrees angle adjustable.  
3.45m (11'-4") stockpile height. (Measured to drum crown).  
61 m<sup>3</sup> (80 yrd<sup>3</sup>) Stockpile capacity.  
Impact bars under feed boot.

## **Mid-Oversize Conveyor:**

900mm (36") wide 3-ply plain belt.  
Hydraulically folding.  
14 to 25 degrees angle adjustable.  
3.3m (10'-9") stockpile height. (Measured to drum crown).  
53.5 m<sup>3</sup> (70 yrd<sup>3</sup>) Stockpile capacity.  
Impact bars under feed boot.  
Variable speed control.

# Technical Specification



WARRIOR 1400 24-01-2007

Page 4

## **Oversize Conveyor:**

1200mm (48") wide 3-ply chevron belt.  
Variable speed control.  
Impact bar along entire length.  
Conveyor slide up system for access to bottom deck meshes.  
10 to 24 degrees angle adjustable.  
3.6 m (11'-10") stockpile height. (Measured to drum crown).  
69.5 m<sup>3</sup> (91 yrd<sup>3</sup>) Stockpile capacity.

## **Powerunit & Hydraulics:**

Diesel engine:	82 kW (109 Hp), developing 74 kW (99Hp) at 2200 rpm.
Flywheel pump:	5046/5033/5033
PTO pump:	5023/5023 (23cc/rev each circuit)
Belt Feeder Motors:	OMSS125 (125cc/rev)
Apron Feeder Motor:	OMTS400 (400cc/rev)
Collection Conveyor Motor:	OMH500 (500cc/rev) – optional OMTS 500
Fines Conveyor Motor:	OMH500 (500cc/rev) – optional OMTS 500
Oversize Conveyor Motor:	OMV800 (800cc/rev)
Mid-Oversize Motor:	OMH500 (500cc/rev) – optional OMTS 500
Screen Motor:	MCC 2208 (58.7cc/rev)

## **Tank Capacities:**

Hydraulic tank:	564 L (124 Gal)
Diesel tank:	336 L (74 Gal)

## **Crawler Track Data:**

Gradability Percentage	=	46.2 % (20.8 degrees)
Gearbox Ratio	=	170.2:1
Hydraulic Motor	=	Rexroth 45 cc/rev
Approximate Speed	=	1.0 Km/hr

## **Options:**

Heavy duty Hardox Apron feeder instead of belt feeder.  
Hardox or mild steel punch plate screens.  
Finger screens on top or bottom decks.  
'Z' meshes complete with ball deck and SCS™ (Self Cleaning Screen).  
Bofor bar top decks.  
Oversize conveyor can be dropped down allowing oversize and mid-oversize product to be combined

14250 [46'-9"]

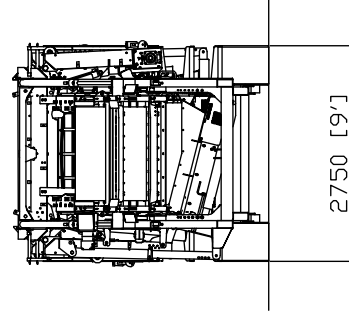
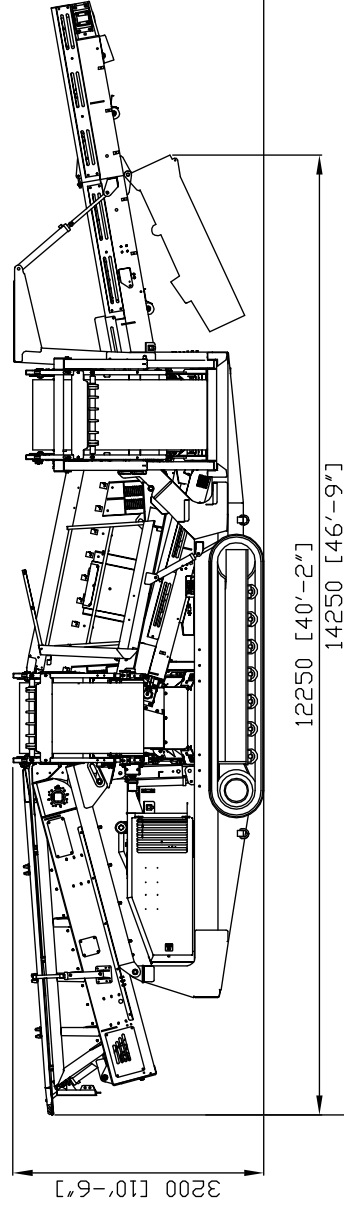
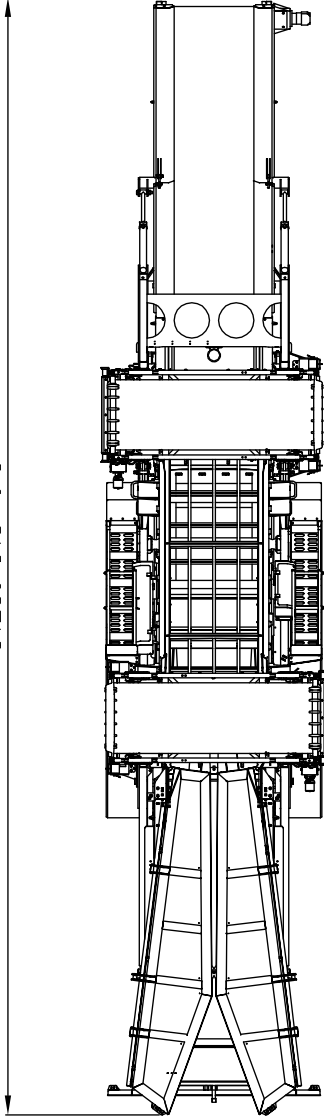

SCALE	DRAWN	DATE	CHECKED	DATE	ISSUE	DATE	REVISION
1:1	AM	06/10/2005					
DRAWING No.		DRAWING TITLE					
		WARRIOR 1400 WITH JACK UP SCREENBOX					



287 GOSWELL ROAD  
LONDON  
E15 4JL  
TEL 0208877 4270  
FAX 0208877 4281  
EMAIL mail@powerscreen.co.uk

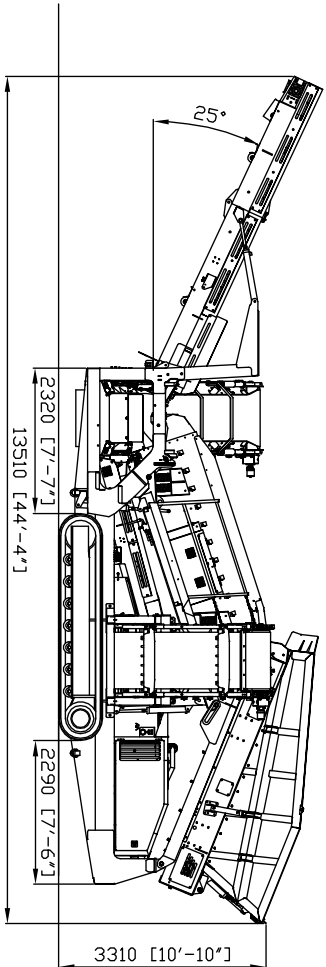
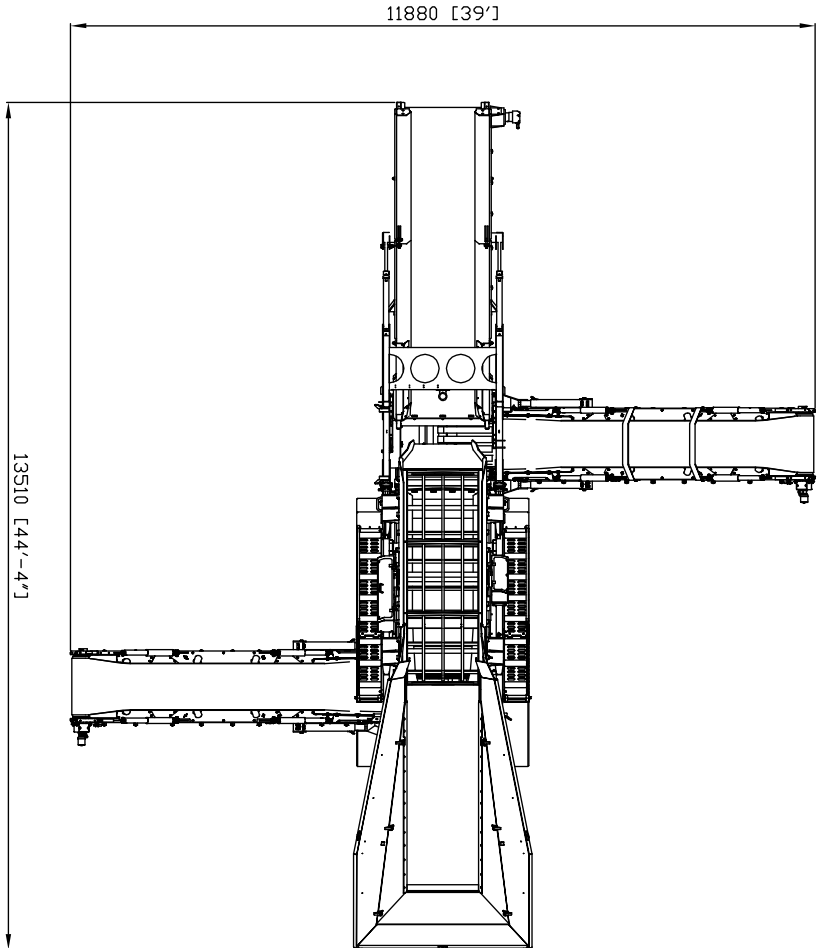
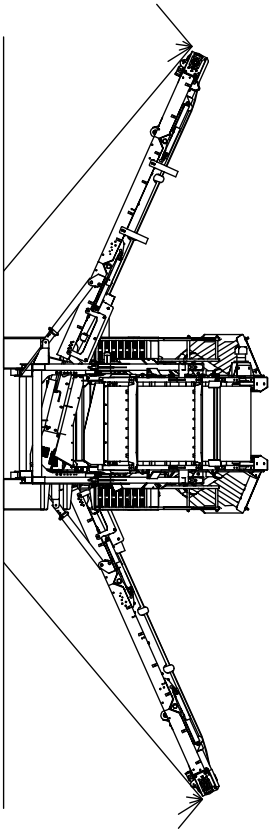

SCALE	DRAWN	DATE	CHECKED	DATE	ISSUE	DATE	BY	REVISION
1:1	AM	10/11/2005						
DRAWING No.		DRAWING TITLE						
		WARRIOR 1400 WITH JACK UP SCREENBOX						

**POWERSCREEN**  
 A Terex Company

807 GUALISTAND RD  
 LAND  
 TEL: 098677 4070  
 FAX: 098677 4231  
 EMAIL: info@powerscreen.co.uk