

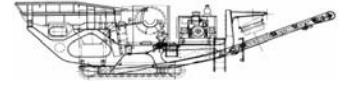

## METROTRAK HA SPECIFICATION



Above image features a Metrotrak fitted with the optional side conveyor and overband magnetic separator

### JAW CRUSHER

- Crusher type:** 'M' Series Single Toggle Jaw with hydraulic setting.
- Feed opening:** 900 x 600 mm.
- Bearings:** Self aligning spherical rollers.
- Lubrication:** Eccentric shaft roller bearings lubricated by grease.
- Drive:** Through wedge belts with screw tension adjustment on engine.
- Factory pre-set:** 50 mm CSS.
- Minimum setting:** 40 mm closed side on concrete. 50 mm CSS on natural rock not exceeding a 10% fines value of 390kN. Settings measured from root to tip of opposite tooth. For applications outside this range, please consult TP.
- Maximum setting:** 100mm CSS (subject to feed grading).
- Adjustment:** Hydraulically adjusted CSS, using two tapered cross beams. Shims not required for adjustment and drawback rod not required.

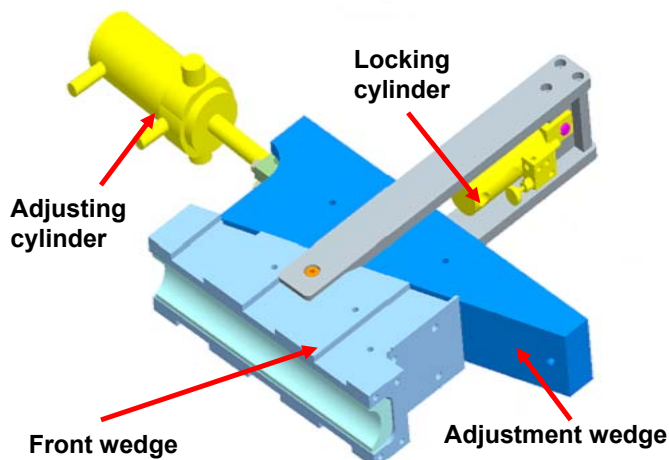
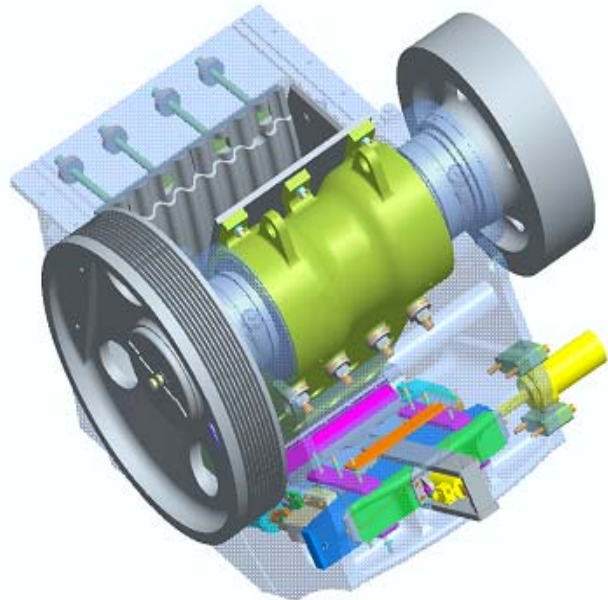

# METROTRAK HA SPECIFICATION

## VIBRATING GRIZZLY FEEDER

<b>Type:</b>	Spring mounted vibrating pan.
<b>Vibrating unit:</b>	Twin heavy-duty cast eccentric shafts running in spherical roller bearings, gear coupled at drive end.
<b>Length:</b>	3800mm.
<b>Width:</b>	800mm.
<b>Drive:</b>	Flange mounted hydraulic motor.
<b>Grizzly:</b>	2.16m long fixed bars at nominal 50mm aperture tapered from front to back, with step and welded into feeder body.
<b>Underscreen:</b>	Removable rubber blanking mat, replaceable with optional wire meshes.
<b>Control:</b>	Variable speed control through a proportional flow control valve.



## HOPPER

<b>Hopper type:</b>	Hydraulic folding feed hopper.
<b>Hopper length:</b>	4m.
<b>Hopper width:</b>	1.8m.
<b>Hopper capacity:</b>	Up to 3.6m <sup>3</sup> gross depending on method of feed.
<b>Hopper body:</b>	8mm thick Hardox wear resistant steel plate with heavy duty reinforcing gussets.



## PLANT CHUTEWORK

<b>Crusher feed chute:</b>	Fabricated in 10mm thick abrasion resistant steel plate sides with 15mm and 25mm thick abrasion resistant bottom and having integral safety grid.
<b>Grizzly by-pass chute:</b>	Fabricated in 6mm thick abrasion resistant steel plate and discharging to the on-plant product conveyor.



## CRAWLER TRACKS

<b>Type:</b>	Heavy-duty tracks fitted as standard.
<b>Pitch:</b>	160mm.
<b>Longitudinal centres:</b>	3300 mm.
<b>Track width:</b>	400 mm.
<b>Climbing grade:</b>	30° maximum.
<b>High speed:</b>	0.9 km/hr
<b>Slow speed:</b>	0.324 km/hr
<b>Drive:</b>	Hydraulic integral motors.
<b>Track tensioning:</b>	Hydraulic adjuster, grease tension.



# METROTRAK HA SPECIFICATION

## ON PLANT PRODUCT CONVEYOR

**Conveyor type:** Troughed belt conveyor with fixed tail end.  
**Belt type:** EP500/3 with 5mm top and 1.5mm bottom heavy-duty rubber covers to BS490 and DIN 22102.  
**Belt width:** 800mm.  
**Discharge height:** 2.9 m.  
**Drive:** Direct drive hydraulic motor.  
**Feedboot:** Fabricated in mild steel plate with abrasion resistant steel liners at feed point.  
**Skirting:** Fully skirted wear resistant rubber sealing along the entire conveyor length.

**Belt adjustment:** Belt tensioning is by use of screw adjustment at the head drum.  
**Belt covers:** Canvas type removable dust covers are fitted at the head end.  
**Belt scraper:** Polyurethane blades are fitted as standard.  
**Lubrication:** Grease lubricated pillow block bearings are provided as follows: -  
*Head shaft:* Two remote fitted to product conveyor.  
*Tail shaft:* Two remote nipples one each side of the main chassis below the feeder.

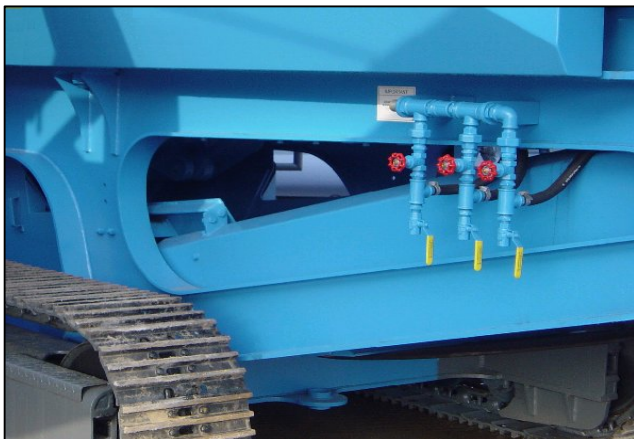

# METROTRAK HA SPECIFICATION

## POWERPACK

**Powerpack type:** Caterpillar 3126B  
**Performance:** 131 kW (175 HP) at 1800 rpm at sea level.  
**Engine:** Six cylinders, four stroke, direct injection.  
**Fuel tank capacity:** 333 Litres

## CLUTCH

**Clutch type:** High efficiency HFO self-adjusting clutch with electro-hydraulic operation.



## DUST SUPPRESSION SPRAYS

Sprays bars with atomiser nozzles are mounted over the crusher mouth and the product conveyor feed and discharge points piped to an inlet manifold for client's pressured water supply.

**Type:** Clean water multi atomising nozzles.  
**Inlet:** Single Point.  
**Pressure required:** 2.8 bar (42 psi).  
**Water supply:** 7 litres per minute.  
**Frost protection:** Via system drain valves.  
**Pump:** **Optional extra.**



## GUARDS

Wire mesh or sheet metal guards are provided for all drives, flywheels, pulleys & couplings.

The guards provided are designed and manufactured to CE & ANSI standards.



## PLATFORMS

Maintenance platforms are provided on each side of the engine and on one side of the crusher feed chute with access ladder.



# METROTRAK HA SPECIFICATION

## TOOLBOX

A plant mounted lockable toolbox is provided containing spare crusher shims, operators manual, hopper wedges, jawstock support cylinder and a grease gun.



## CHASSIS

Heavy duty fabricated I section of welded construction.



## PLANT CONTROLS

Controls are fitted onto the plant to operate the following items: -

- Feeder (Stop/Start/Speed)
- Optional Dirt Conveyor (Start/Stop)
- Product Conveyor (Start/Stop)
- Crusher (Start/Stop)
- Crusher clear assist
- Emergency stop



## UMBILICAL CONTROL

An umbilical control unit is also supplied with the plant. This is fitted with controls for the track motion, feeder stop, start and a stop button for the plant.



# METROTRAK HA SPECIFICATION

## OPTIONAL EXTRAS

(For prices refer to your dealer)

- Side/dirt conveyor.
- Radio remote control (subject to local approval).
- Magnetic overband separator.
- Wire meshes for underscreen; aperture options are 10mm, 20mm, 30mm, 40mm and 50mm separation. Optional dirt conveyor must be added with this option.
- Electrically driven 24v fuel transfer pump assembly.
- Single idler belt weigher with integrator and speed sensing wheel fitted to main product conveyor.

## **RECOMMENDED OPTIONAL EXTRAS**

- Camera mounted over crusher mouth with remote screen facility in operators cabin.
- Hydraulic driven water pump assembly to provide a pressurised water supply to the dust suppression sprays.
- Engine fire extinguisher system.

## MAGNET (OPTIONAL EXTRA)

<b>Magnet type:</b>	Suspended self-cleaning overband, fitted with endless belt.
<b>Magnet width:</b>	531mm.
<b>Magnet length:</b>	836mm.
<b>Drive:</b>	Hydraulic Motor.
<b>Control:</b>	Pre-set variable speed.
<b>Discharge chute:</b>	Via stainless steel shedder plate.
<b>Power:</b>	570 Gauss at 200mm. 450 Gauss at 250mm.



## ON PLANT DIRT/SIDE CONVEYOR (OPTIONAL EXTRA)

<b>Conveyor type:</b>	Troughed belt conveyor, hydraulic folding for transport.
<b>Width:</b>	600mm.
<b>Discharge height:</b>	2m.
<b>Drive:</b>	Direct drive hydraulic motor.
<b>Lubrication:</b>	Lubrication pillow block bearings are provided as follows: -
<i>Head shaft:</i>	One nipple is located on each bearing housing.
<i>Tail shaft:</i>	Two remote nipples on one side of the main plant chassis below the feeder.
<b>Position:</b>	Mounted to discharge on near side of plant.
<b>Function:</b>	To collect fines passing through grizzly bars and/or underscreen mesh and discharges to side of plant provided quantity of fines is not excessive.



# METROTRAK HA SPECIFICATION

## REMOTE CONTROL (OPTIONAL EXTRA)

This option will control the tracking function and also provides stop and start controls for the vibrating grizzly feeder, together with a stop button for the plant. **This facility is only available in certain countries where type approval has been obtained.** For a full list of countries, please consult TP or your dealer.



## PLANT DIAGRAM

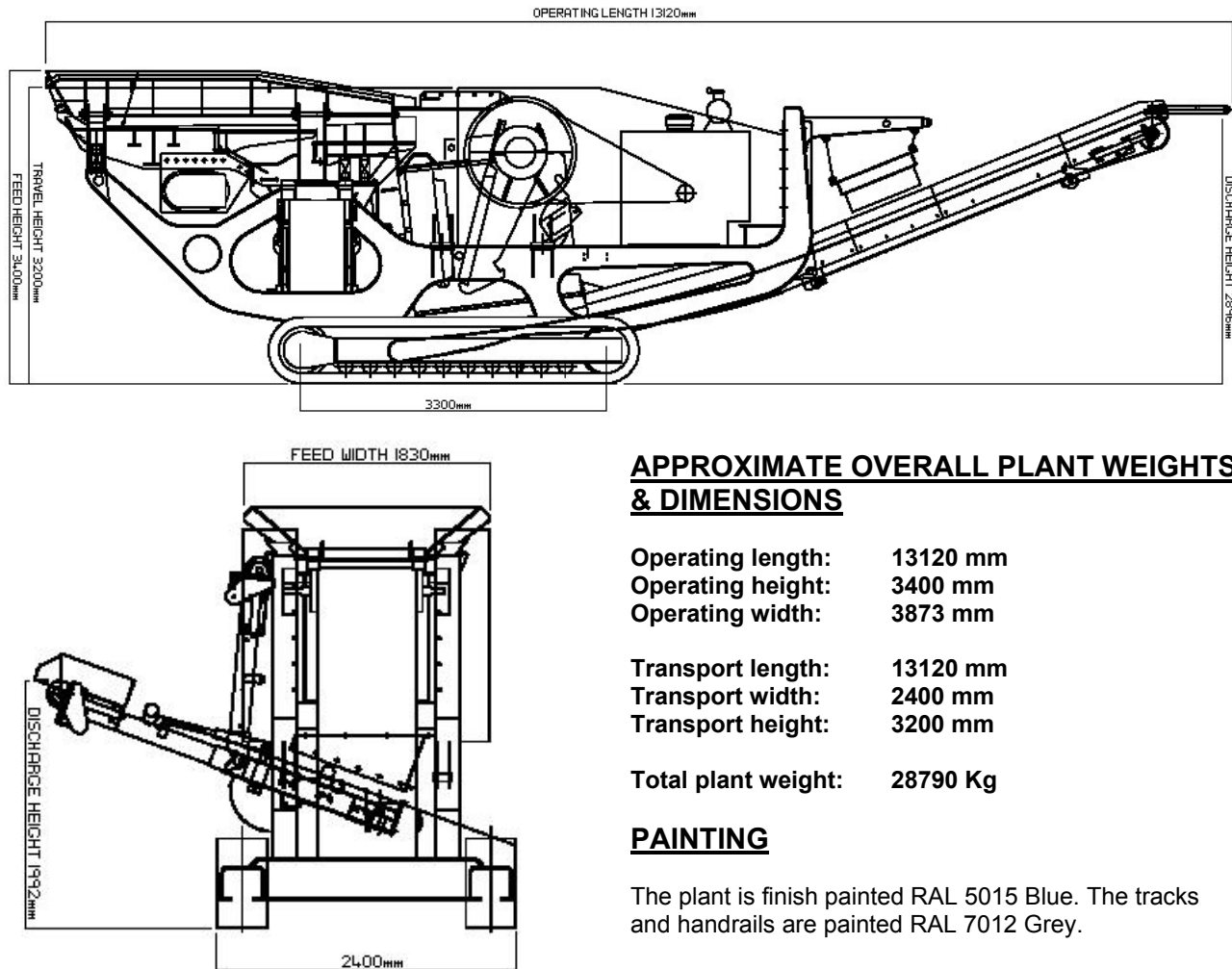

## APPROXIMATE OVERALL PLANT WEIGHTS & DIMENSIONS

Operating length:	13120 mm
Operating height:	3400 mm
Operating width:	3873 mm
Transport length:	13120 mm
Transport width:	2400 mm
Transport height:	3200 mm
Total plant weight:	28790 Kg

## PAINTING

The plant is finish painted RAL 5015 Blue. The tracks and handrails are painted RAL 7012 Grey.

## General

TEREX | Pegson equipment complies with CE requirements.

Above line drawings feature a Metrotrak with optional side conveyor and overband magnetic separator.

The plant is designed to operate between ambient temperatures of between -10c and 40c at altitudes up to 1000 meters above sea level. For applications outside this range please consult with Terex Pegson Limited.

Please consult TEREX | Pegson if you have any other specific requirements in respect of guarding, noise or vibration levels, dust emissions, or any other factors relevant to health and safety measures or environmental protection needs. On receipt of specific requests we will endeavour to ascertain the need for additional equipment and, if appropriate, quote extra to contract prices. Every endeavour will be made to supply equipment as specified, but we reserve the right, where necessary, to amend specifications without prior notice as we operate a policy of continual product development. It is the importers responsibility to check that all equipment supplied complies with local legislation.

Metrotrak HA Specification MT960HA/204.