



Innovation at Work

TRT622

FEATURES AND BENEFITS

EDGE® TRT622

Features & Benefits



EDGE® TRT622

CONTENTS

- General Design Features
- Hopper
- Conveyors
- Drum (Barrel)
- Powerunit
- Tanks
- Hydraulic Components
- Manual Controls
- Control Panel
- Tracks
- Tracking
- Radio Remote Handset
- Technical Dimensions
- Options List

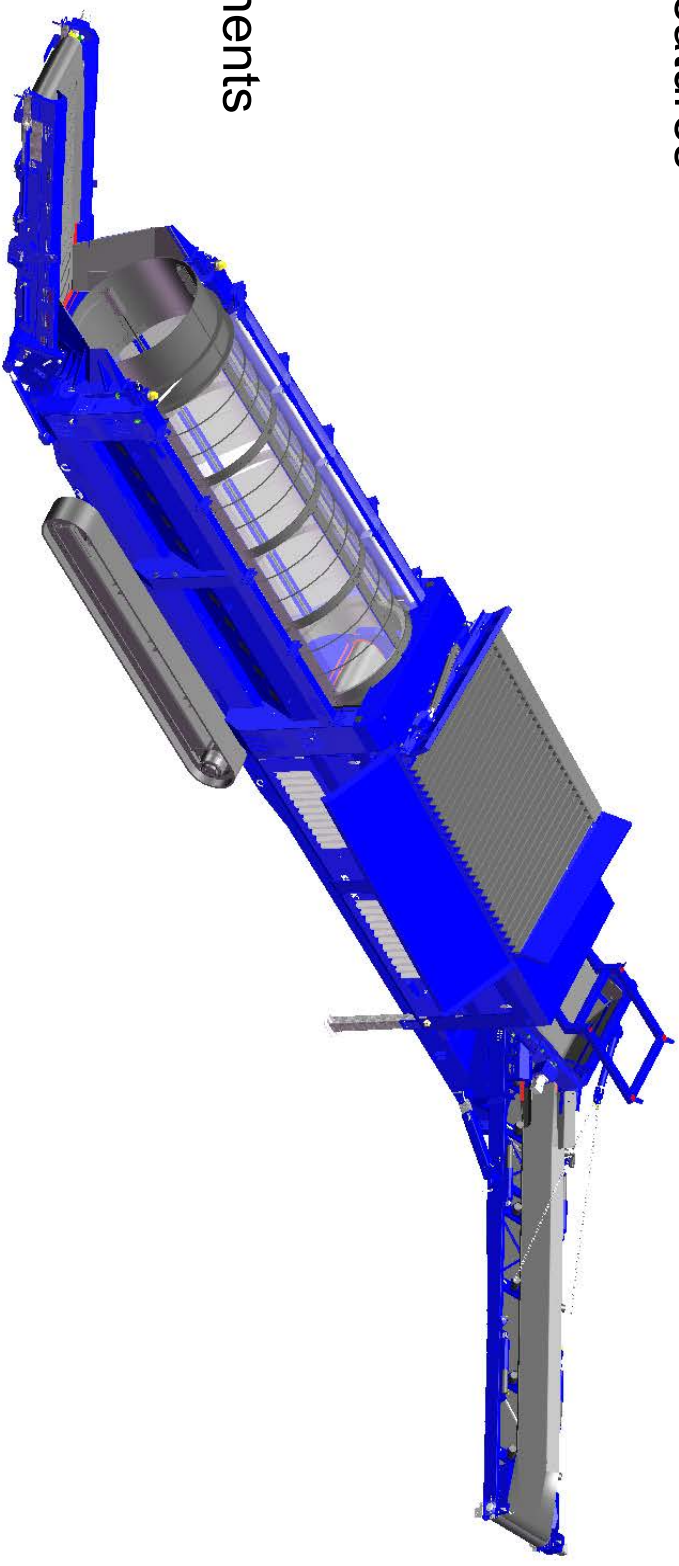

Innovation at Work

EDGE® TRT622

DESIGN

- Designs features include; a highly efficient hydraulic drive system
- Intelligent hydraulic load sensing system
- 8 function remote control
- Variable discharge height for maximum stockpiling
- Hydraulic jack up for low loader transportation
- Impact bars on oversize conveyor
- 60" wide collection conveyor
- 48" wide feeder belt to minimise material hopper bridging
- Easily removable drum and rapid drum exchange procedure

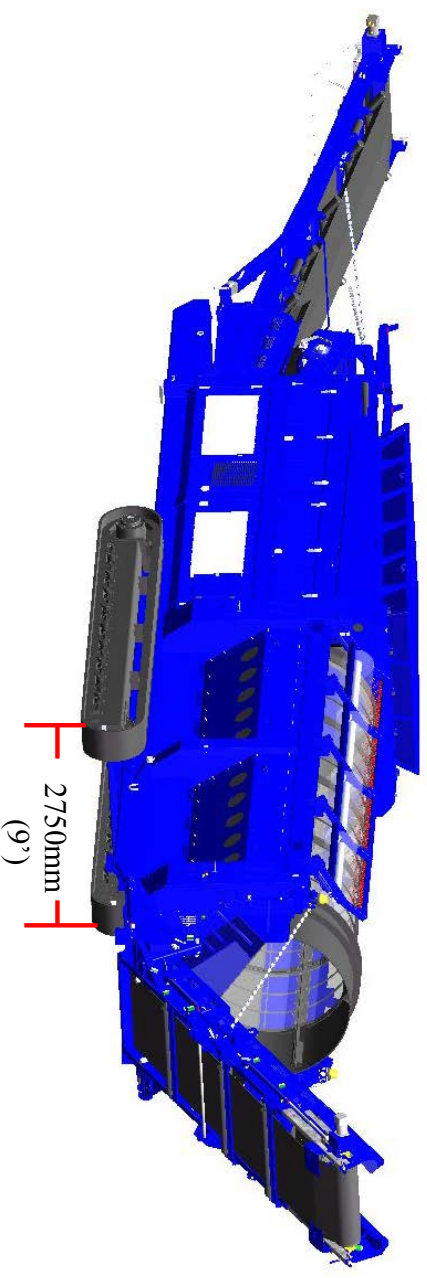

- Overall stability is improved by a track frame width of: 2750mm(9') and hydraulic galvanised Jacklegs
- Machine durability is provided with conveyor side plate thickness of 6mm (0.24") and conveyor side frame depth ranging from 390mm to 260mm (15"/10")



EDGE® TRT622

Hopper

- Hopper Capacity 4.1m³ (145 cubic ft)
- Ability to start fully loaded with material
- 1200mm (48”) wide feeder belt
- Heavy duty centre rollers to take impact from feeding material
- Hopper sides reinforced with box section
- Options of having remote tipping grid or live head.

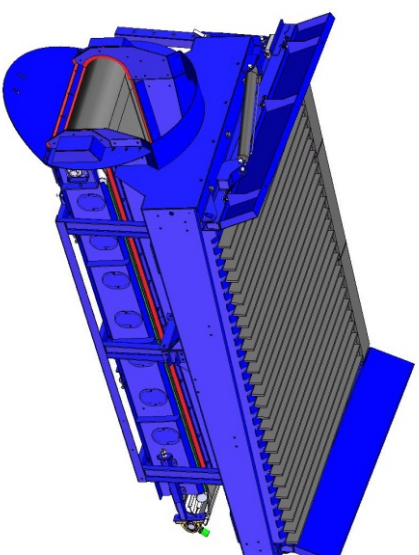

EDGE® TRT622 Feeder Conveyor

- Direct drive system and hydraulic variable speed control. Intelligent hydraulic load sensing system to prevent overload.
- Hydraulically sliding feeder conveyor allows for an easy drum exchange procedure
- Spoked tail drum to prevent foreign objects from damaging conveyor belt.
- Internally driven allowing for ease of maintenance.

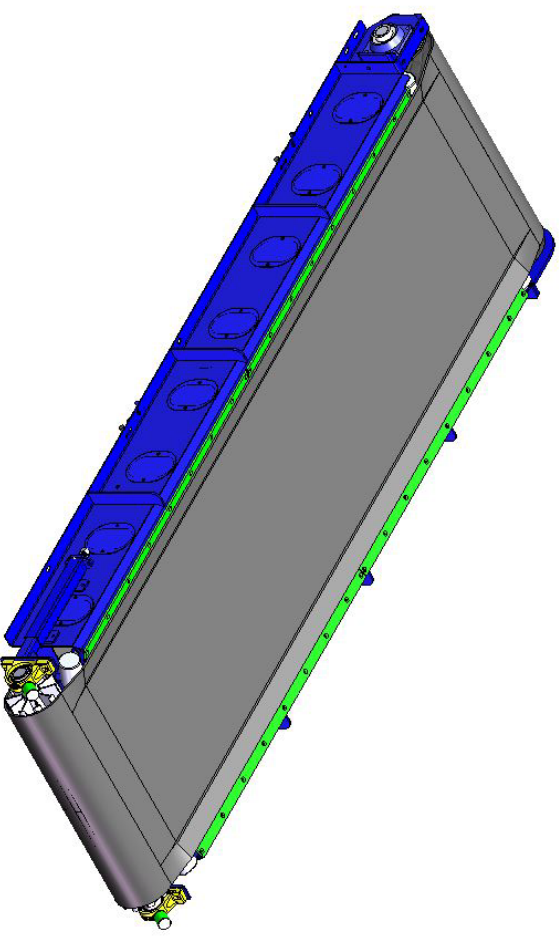

Innovation at Work

EDGE® TRT622 Feeder Conveyor

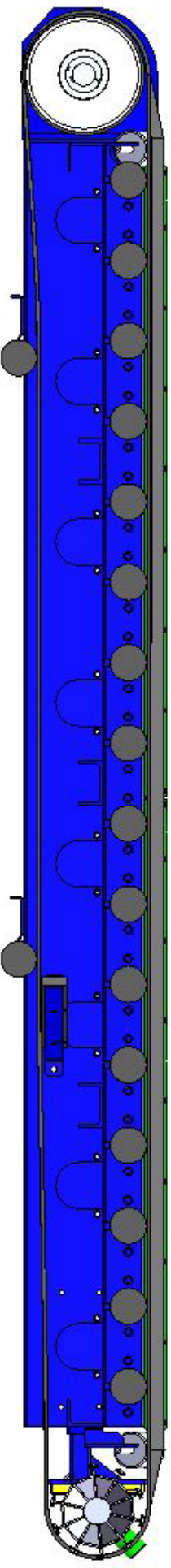

- 1300mm (51") long diamond lagged drive drum
- 1250mm (49") long Spoked tail drum
- Belt Length: 9170mm (30')
- Self lubricating grease system
- Hydraulically driven via a Brevini gearbox and Sauer Danfoss motor



Innovation at Work

EDGE® TRT622

Collection Conveyor

- New 1500mm (60") wide conveyor belt.
- Upgraded Belt scraper
- Spoked tail drum to prevent foreign objects from damaging conveyor belt
- Hydraulically driven by a Sauer Danfoss motor

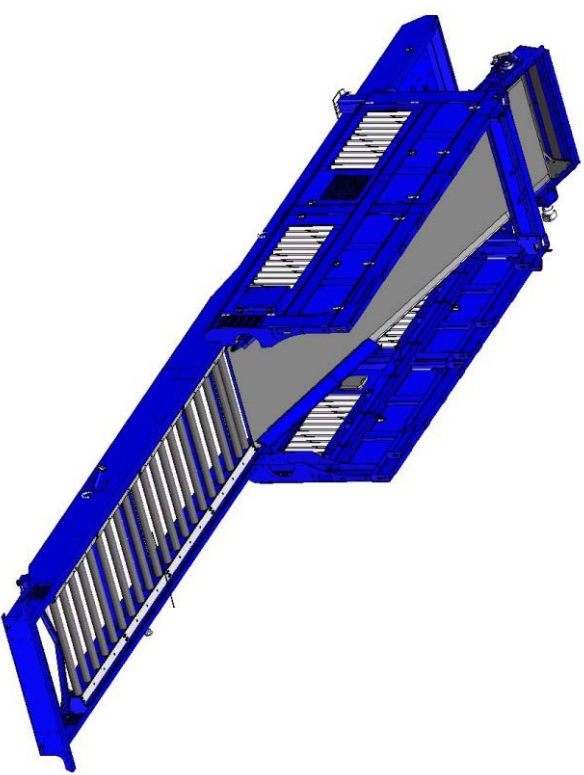
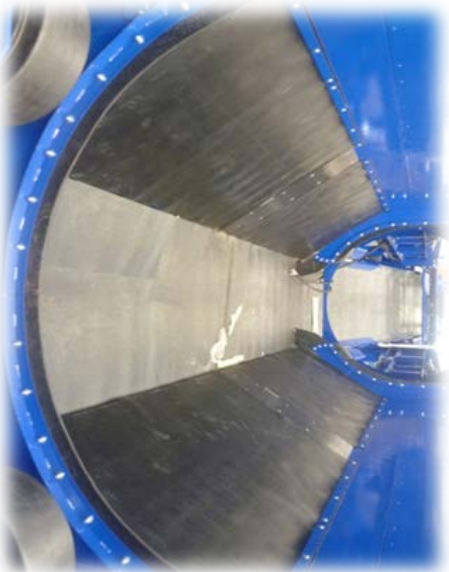

Innovation at Work

EDGE® TRT622

Oversize Conveyor

- Galvanised telescopic head section
- Heavy duty 1050mm (42") wide chevron belt
- Discharge height of 2.8m (9ft)
- Impact bars on oversize conveyor to take the impact from screen material, prolonging the life of the conveyor belt
- Hydraulically folding to give a shorter transport length
- Highly robust design

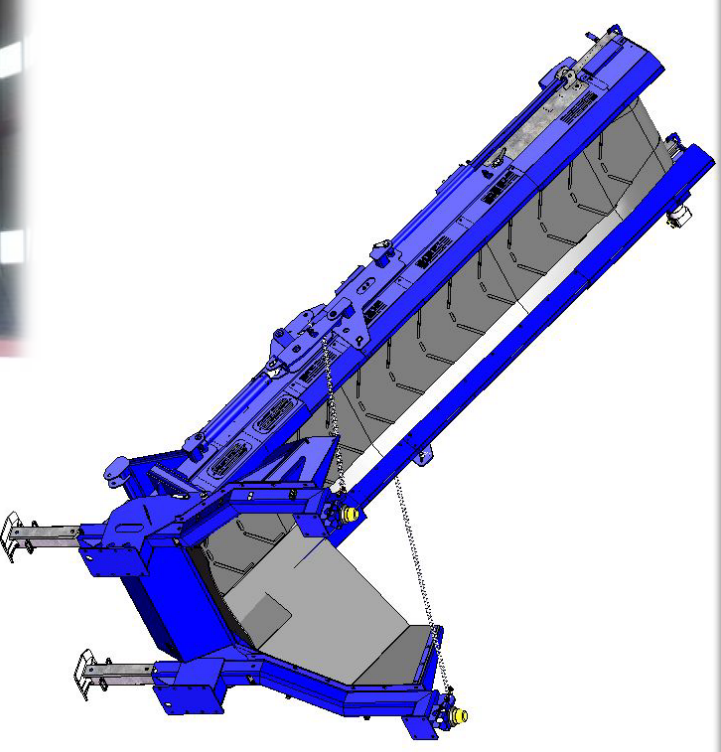

Innovation at Work

EDGE® TRT622 Oversize Conveyor

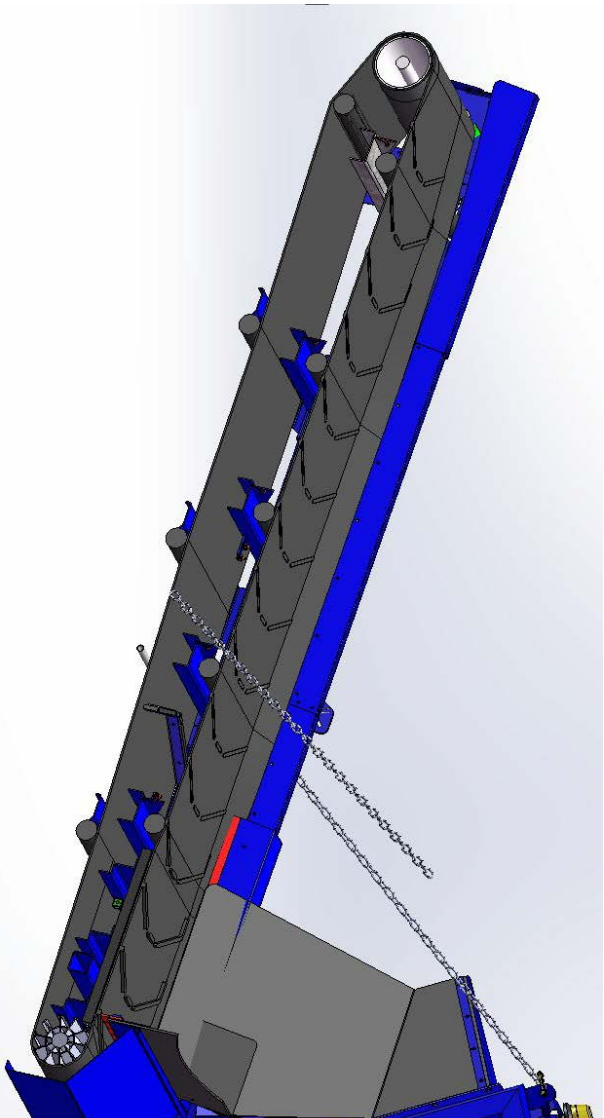

- 1120mm (44") long diamond lagged drive drum
- 1100mm (43") long spoked tail drum to prevent foreign objects from damaging conveyor belt
- Self Lubricating grease system
- Hydraulically driven by a Sauer Danfoss motor
- Belt Length: 11050mm (36'3")



Innovation at Work

EDGE® TRT622 Radial Conveyor

- 1050mm (42") wide belt.
- 180° Radial swing
- Variable discharge height
- Provides a stockpile volume of 1056m³ (1381 cubic yards)
- Galvanised telescopic supports are fitted with inner and outer high tensile anti-wear bushings.
- Controlled via radio remote
- Hydraulically folding for transport

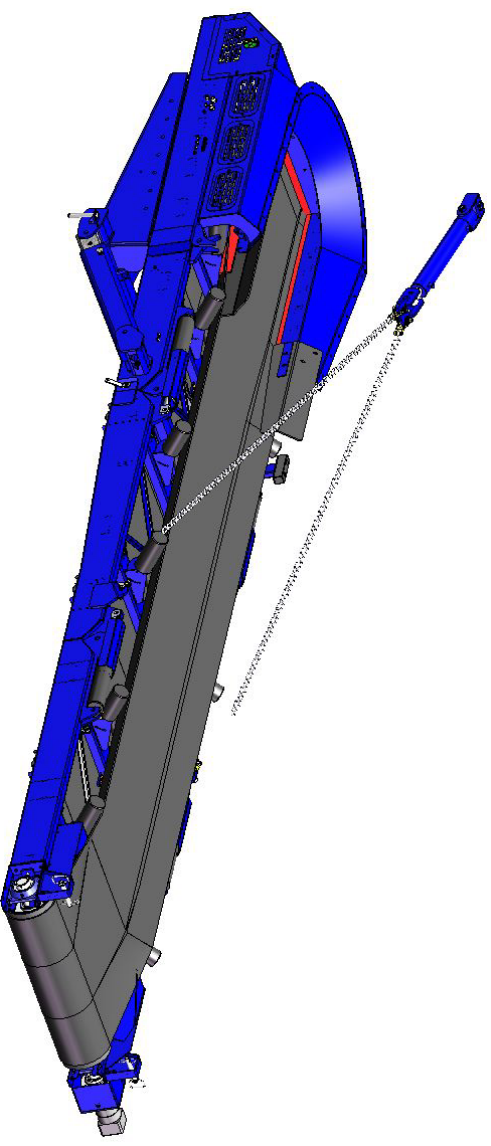

EDGE® TRT622 Radial Conveyor

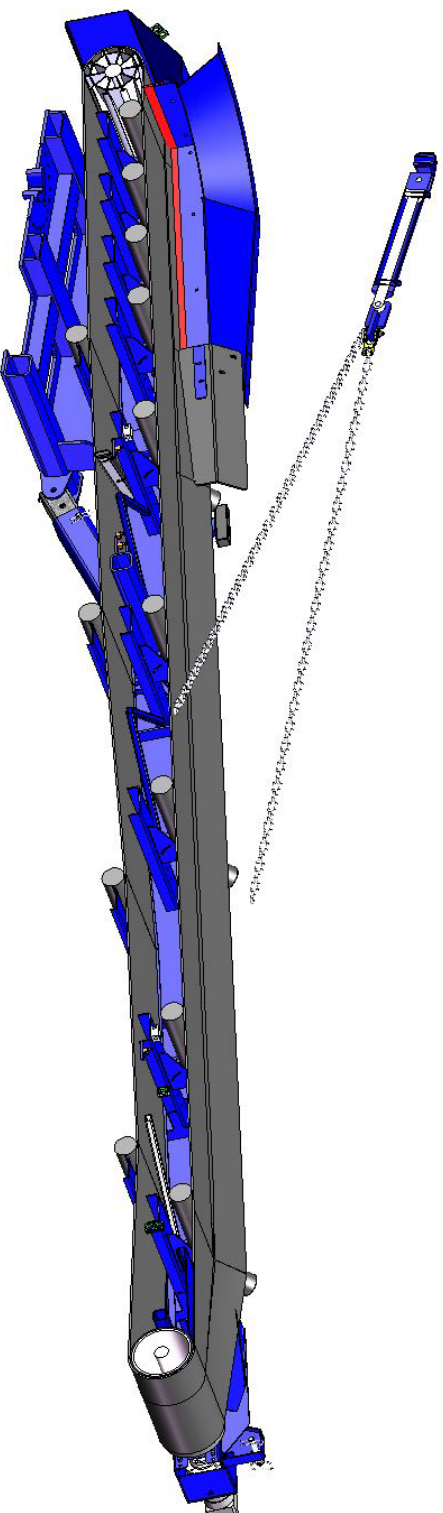

- 1120mm (44") long diamond lagged drive drum
- 1100mm (43") long spoked tail drum to prevent foreign objects from damaging conveyor belt
- Self Lubricating grease system
- Hydraulically driven by a Sauer Danfoss motor
- Belt Length: 15730mm (51'7")



Innovation at Work

EDGE® TRT622

Drum (Barrel)

- 2m (6'7") drum diameter
- 6.9m (22'6") drum length
- Screening area of 24.8m³ (32 cubic yards)
- Adjustable screening angle ranging from 0°-5°
- Hydraulic adjustable brushes
- Easily exchangeable drum for maintenance.
- Various aperture meshes, punch plate panels, fully welded punch plate drums with scrolls



EDGE® TRT622

Drum (Barrel)

- Drum is driven via a hydraulic 4 wheel drive system consisting of four Poclain MS02 398cc displacement motors providing;
- A variable drum speed ranging from 0-24RPM and;
- Reversible drum rotation



Innovation at Work

EDGE® TRT622 Powerunit

- Powered by a CATERPILLAR C4.4ATAAC ACERT Industrial Power Unit - EPA Tier III / EU, Stage 3A compliant engine
- 96kw (129hp) at 2100RPM
- Idle Speed of 800RPM
- Operational Speed of 1800RPM increasing to 2100RPM whilst tracking
- Low fuel consumption of 12-15 Ltr/hr. (3-4US gallons)
- Powerunit frame can be lowered from main chassis in order to provide access to engine and hydraulic components.



EDGE® TRT622 Hydraulic Tank

- 950ltr (250USG) Hydraulic Tank
- Filters located at the side of the unit for ease of maintenance
- Multiple stage filtration system ensuring the removal of any foreign particles



Innovation at Work

EDGE® TRT622 Diesel Tank

- 350ltr (92USG) Diesel Tank
- Industrial size, lockable diesel filler cap
- Easily accessible for maintenance



Innovation at Work

EDGE® TRT622

Hydraulic Components

- Danfoss Tandem Series 45 variable displacement pumps (900cc/rev)
- Provides power to two Sauer Danfoss PVG Valves which in turn control the conveyors, drum and tracks
- Cetop 3, double acting blocks allows for the jacklegs and raise/lower chassis to be activated via radio remote or control panel
- All major hydraulic components are easily accessible for the purpose of maintenance



EDGE® TRT622

Manual Controls

- User-friendly manual controls for set-up and operation
- Each control lever is clearly identified by operational decals.

Depending on options specified. Control lever functions on the Trommel include;

- Drum Angle
- Raise/Lower Cleaning Brushes
- Oversize raise/lower, fold in/out and to extend/retract the Oversize conveyor head section.
- Position of the Feeder conveyor.
- Swivelling of the Radial conveyor, raise/lower tilt table, raise/lower radial conveyor, raise/lower Radial conveyor support, fold/unfold Radial mid-section and fold/unfold Radial conveyor head section.



- The HMI Control Panel Interface provides easy fine tuning for accurate application performance.
- HMI interface screen allows for automatic start / stop operation & to run each function individually
- Engine load, PVG valve pressures, hydraulic oil temp & fuel consumption displayed while machine is still operating.
- All engine info & diagnostic faults accessed through screen





This is the Main Menu, from here the user may enable certain functions or navigate to various other menus by pressing the appropriate button

1. Run Menu
2. Machine Setup/Tracking Menu
3. Fault Log Menu
4. User Program Settings
5. Siren Test/Radio Active
6. Engine Feedback Screen
7. Information Screen
8. System Settings

Left Arrow - Decrease engine speed

Right Arrow - Increase engine speed

In the centre of the screen are 3 gauges top is the Fuel gauge, centre is the engine water temp and at the bottom is the current engine speed.

EDGE® TRT622 Tracks

- Full site mobility provided through the hydraulic driven crawler tracks
- Track Length of 5046mm (16'6")
- Track Shoe Width of 400mm (16")
- 2100RPM can be utilised to drive tracks



- Trommel can be tracked via the radio remote or doglead.
- The Doglead is an independent unit that tracks the movement of the machine.
- The manual doglead can be used in any screen, to activate the user should switch on the handset by pressing the On/Off switch.
- A siren will sound to alert that the tracking mode is active and after a 7 second delay the tracks may be operated by pressing the directional switches.

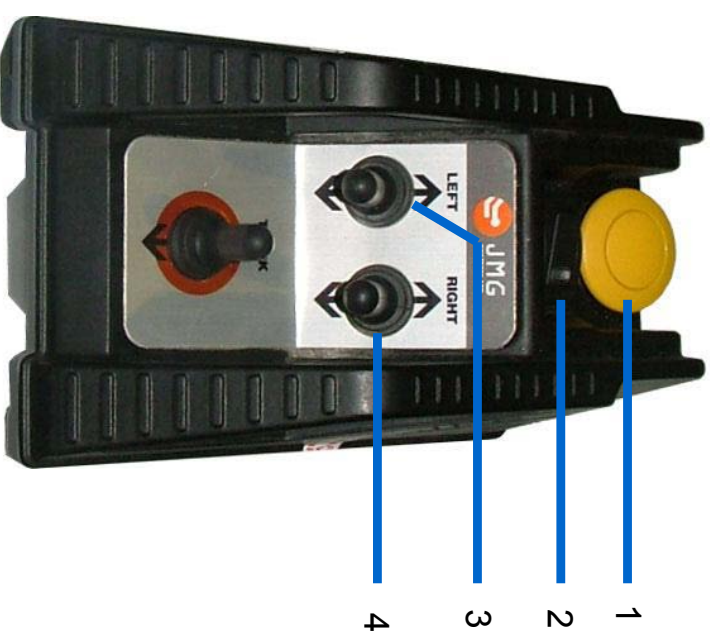

- ITEM 1:** Engine Stop Button
- ITEM 2:** Tracks On/Off Switch - A green L.E.D. will illuminate when the switch is in the on position
- ITEM 3:** Right hand track forward/reverse switch
- ITEM 4:** Left hand track forward/reverse switch

EDGE® TRT622 Radio Remote Handset



A number of features can be controlled via the radio remote. Including;

- Start / Stop machine functioning
- Tracks
- Tipping grid with timed up / down function
- Raise / lower chassis or jacking legs
- Variable engine speed 800 – 2100RPM
- Rotate radial conveyor
- Variable feeder speed
- Machine shutdown button

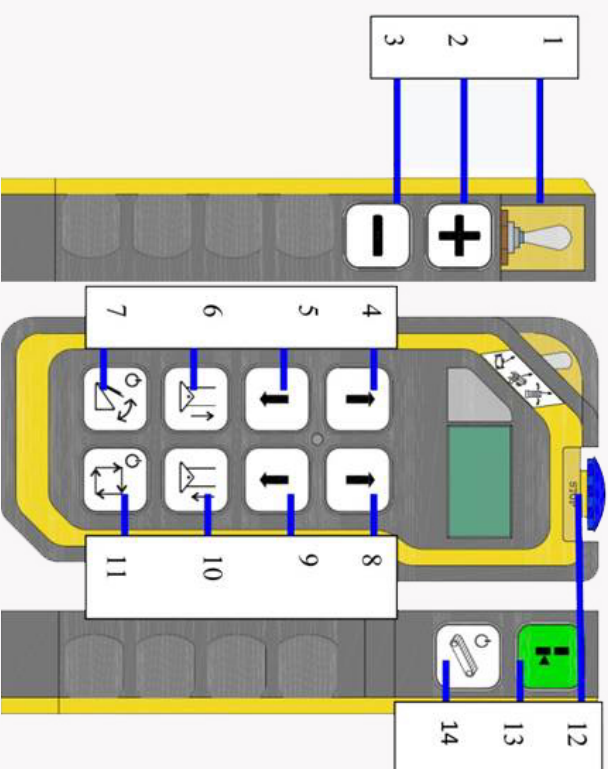

No	Description
1	Engine/Feeder/Radial Selector Switch
2	Increase/Right
3	Decrease/Left
4	Left Track Forward*
5	Left Track Reverse*
6	Jackleg Raise
7	Tip Hopper
8	Right Track Forward*
9	Right Track Reverse*
10	Jackleg Lower
11	Auto Cycle On/Off
12	Transmitter Off / Engine Stop
13	Transmitter On
14	Track Enable *



EDGE® TRT622

Working Dimensions

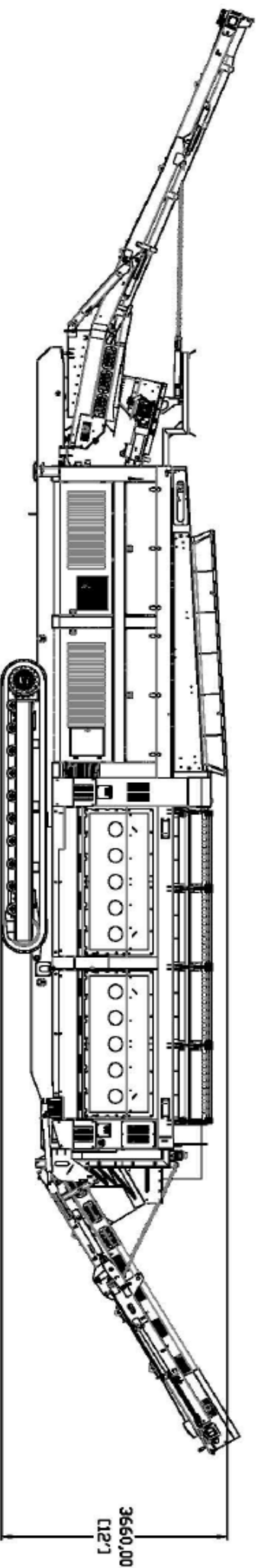

Minimum Load Height

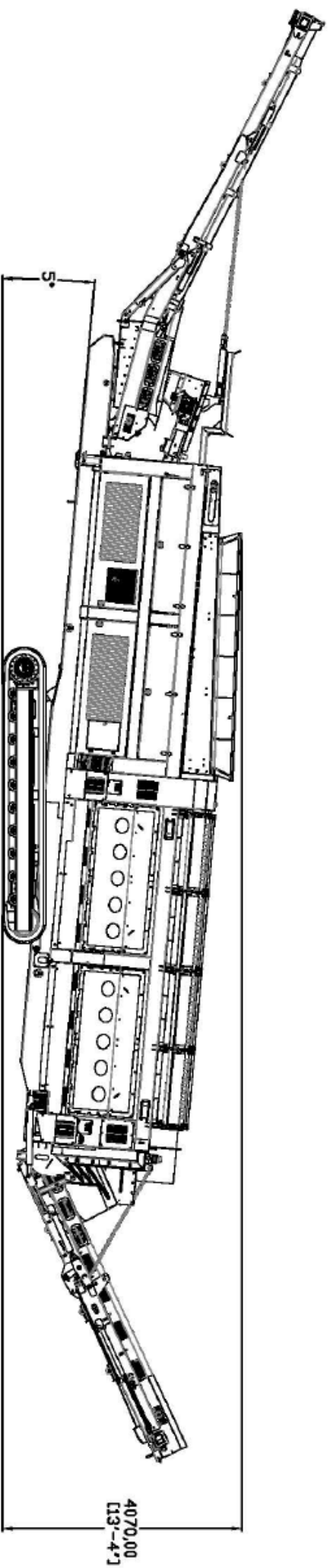

Maximum Load Height



Innovation at Work

EDGE® TRT622

Transport Dimensions

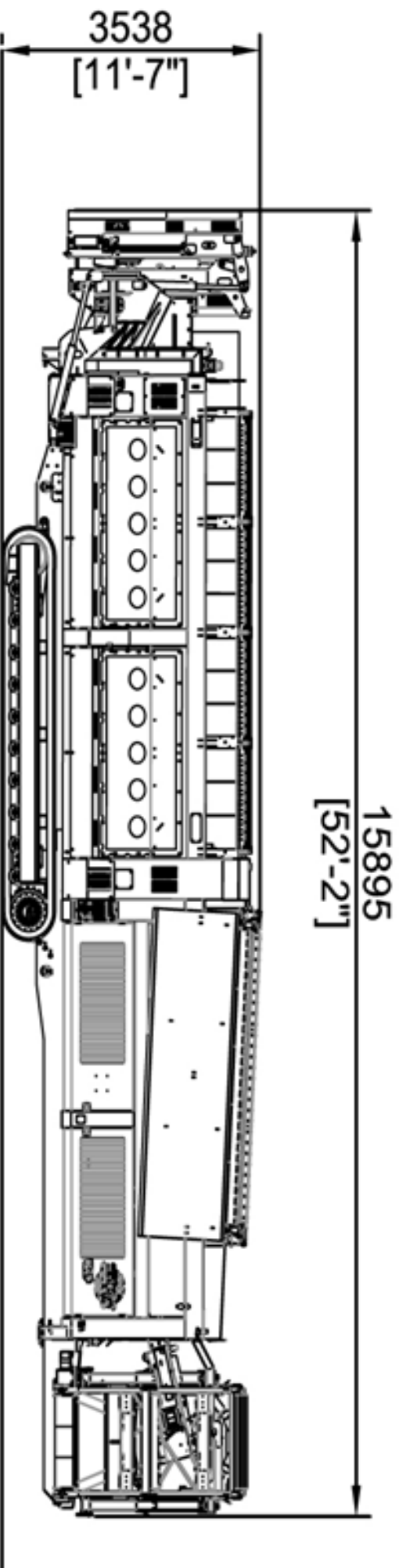

Oversize conveyor transport position



Radial conveyor transport position



Innovation at Work

EDGE® TRT622

Stockpile Volumes

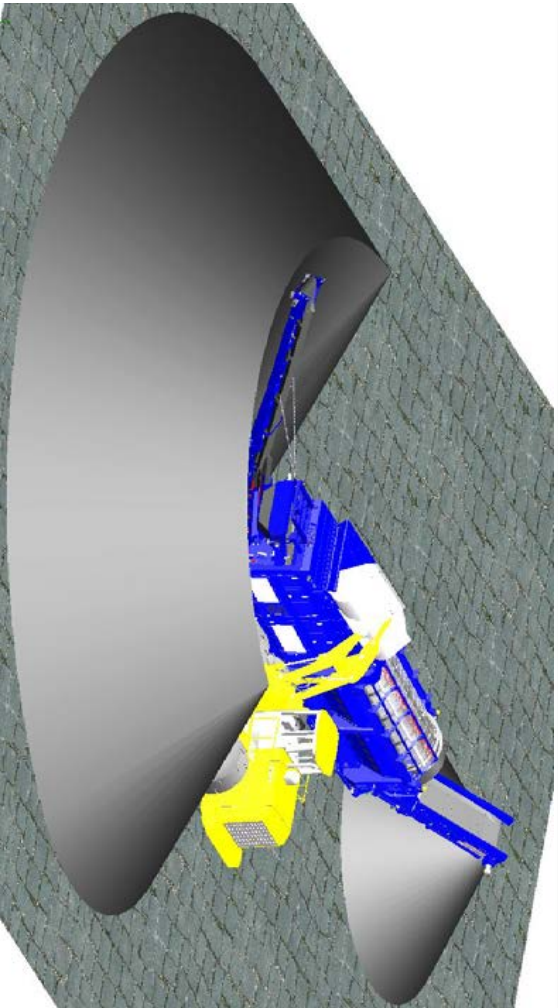

Radial Stockpile Volume: 1056m³ (1381 cubic yards)

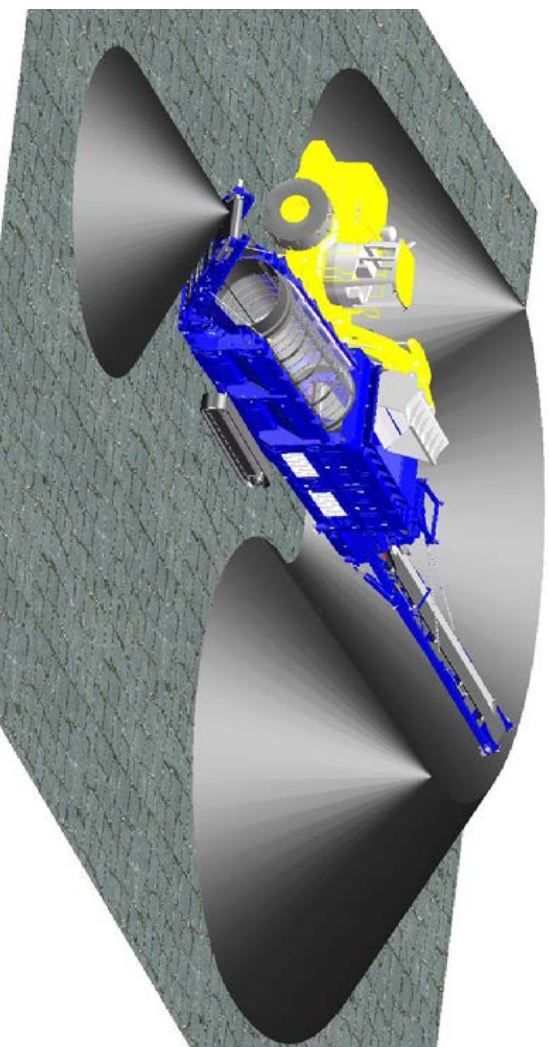

Oversize Stockpile Volume: 34m³ (44 cubic yards)



Innovation at Work

EDGE® TRT622

Options List

Magnetic Head Drum (Radial)



Multiple Drums and Screen combinations



Remote Tipping Grid with various apertures



- Vibrating grid with remote control tipping
- Reversible fan
- Hydraulic blowers / air knives
- Remote control to radial conveyor
- Impact Bed/Rollers in Feeder Conveyor
- Hardox lined Hopper
- Grease lines
- Auto-Lube system
- Heavy Duty Belts
- Double cleaning brushes
- Auxiliary couplings
- Tipping grid / Vibrating grid deflector chute
- Dust suppression system

Overband Magnet



http://www.youtube.com/watch?v=04WzIsCXD9Q&feature=share&list=UUeA3ZS_ID5Bx1_jiELD

WtA



Innovation at Work

EDGE® FS-SERIES



EDGE® Innovate (NI) Ltd, Head Quarters, 30 Farlough Road, Dungannon, Co. Tyrone, NI BT71 4DT

T: +44 (0)28 8774 0525 **E:** info@edgeinnovate.com **F: + 44 (0) 2887 747244** **W:** www.edgeinnovate.com

The units depicted show all options currently available. Current models may differ from those featured in this brochure. Please contact EDGE® to clarify specifications and options. The material in this brochure is of general application for information and guidance only and no representation or warranty is made or given by the manufacturer that its products will be suitable for a customer's particular purpose and enquiry should always be made of the manufacturer to ensure such suitability. Whilst reasonable efforts have been made in the preparation of this document to ensure its accuracy. The manufacturer assumes no liability resulting from errors or omissions in this document or from the use or interpretation of the information contained herein. The manufacturer reserves the right to make changes to the information in this brochure and the product design without reservation and without notification to users.



Innovation at Work